

PSM-ME-RS232/RS232-P

Interface converter for the electrical isolation of RS-232 interfaces

Data sheet
100276_en_04

© PHOENIX CONTACT 2016-09-15



1 Description

The interface converter **PSM-ME-RS232/RS232-P** is used for electrical isolation of RS-232 interfaces.

The interface converter is snapped onto standard EN DIN rails in the switch cabinet and supplied with 24 V DC or AC.

Features

- Maximum transmission speed of 115.2 kbps
- High-quality 3-way isolation up to 2 kV (VCC // V.24 (RS-232) // TTY)
- Integrated surge protection with transient discharge to the DIN rail
- Transmission speed up to 115.2 kbps
- Transmission of TxD/RxD data channels and RTS/CTS control lines
- Active data transmission indicated by separate data indicators for the transmit and receive channels



Make sure you always use the latest documentation.
It can be downloaded from the product at phoenixcontact.net/products.

2	Table of contents	
1	Description	1
2	Table of contents	2
3	Ordering data	3
4	Technical data	3
5	Safety notes	6
5.1	UL Notes	6
6	Application examples	7
7	Structure	8
7.1	Dimensions	8
7.2	Block diagram	8
7.3	Function elements	9
8	RS-232 interface	10
8.1	DTE/DCE adjustment	11
8.2	COMBICON pin assignment	12
8.3	Connecting the data cables	12
9	Assembly	13
9.1	Removal	13
9.2	Power supply	13

3 Ordering data

Description	Type	Order No.	Pcs./Pkt.
Interface converter, for the isolation of RS-232 (V.24) interfaces, 4 channels, rail-mountable	PSM-ME-RS232/RS232-P	2744461	1
Accessories	Type	Order No.	Pcs./Pkt.
RS-232 cable, 9-pos. D-SUB socket 25-pos on D-SUB socket	PSM-KA 9 SUB 25/BB/2METER	2761059	1
RS-232 cable, 9-pos. D-SUB socket on 9-pos. D-SUB socket, 9-wire, 1:1	PSM-KA9SUB9/BB/2METER	2799474	1
Shield connection clip for printed circuit terminal block	ME-SAS	2853899	10
Actuation tool, for ST terminal blocks, also suitable for use as a bladed screwdriver, size: 0.6 x 3.5 x 100 mm, 2-component grip, with non-slip grip	SZF 1-0,6X3,5	1204517	10

4 Technical data

Supply	
Supply voltage range	19.2 V AC/DC ... 28.8 V AC/DC
Nominal supply voltage	24 V AC/DC \pm 20 %
Typical current consumption	40 mA (24 V DC)
Protective circuit	Surge protection (Suppressor diode)
Electrical isolation	VCC // V.24 (RS-232) (A) // V.24 (RS-232) (B)
Test voltage data interface/power supply	2 kV _{rms} (50 Hz, 1 min.)
Torque	0.56 Nm ... 0.79 Nm
V.24 (RS-232) interface in acc. with ITU-T V.28, EIA/TIA-232, DIN 66259-1	
Transmission channels	4 (2/2), RxD, TxD, RTS, CTS; full duplex
Connection method	D-SUB 9 plug
Conductor cross section	0.2 mm ² ... 2.5 mm ² (24 AWG ... 13 AWG)
Serial transmission speed	115.2 kbps
Transmission length	15 m (shielded twisted pair)
Protocols supported	transparent protocol
Pin assignment	DTE/DCE switchover via switch

V.24 (RS-232) interface in acc. with ITU-T V.28, EIA/TIA-232, DIN 66259-1

Connection method	Pluggable screw connection
Transmission length	15 m (shielded twisted pair)

General data

Degree of protection	IP20
Dimensions (W/H/D)	22.5 mm x 99 mm x 118.6 mm
Housing material	PA green
Bit distortion	< 5 %
Bit delay	< 3 μ s
Noise emission according to	EN 61000-6-3
Noise immunity according to	EN 61000-6-2:2005
Electromagnetic compatibility	Conformance with EMC Directive 2014/30/EU
Transmission channels	4 (2/2), RxD, TxD, RTS, CTS; full duplex

Ambient conditions

Ambient temperature (operation)	0 °C ... 55 °C
Ambient temperature (storage/transport)	-40 °C ... 85 °C
Permissible humidity (operation)	10 % ... 95 % (non-condensing)
Altitude	5000 m (For restrictions see manufacturer's declaration)

Approvals / Certificates

Conformance	CE-compliant EAC
UL, USA/Canada	508 recognized Class I, Div. 2, Groups A, B, C, D Class I, Zone 2, AEx nA IIC T4 Class I, Zone 2, Ex nA IIC T4 Gc X
Shipbuilding approval	DNV

Conformance with EMC Directive 2014/30/EU**Noise immunity according to EN 61000-6-2**

Electrostatic discharge	EN 61000-4-2	
	Contact discharge	± 6 kV (Test Level 3)
	Discharge in air	± 8 kV (Test Level 3)
	Comments	Criterion B
Electromagnetic HF field	EN 61000-4-3	
	Frequency range	Test Level 3
	Field intensity	10 V/m
	Comments	Criterion A
Fast transients (burst)	EN 61000-4-4	
	Input	± 4 kV (5 kHz)
	Signal	± 2 kV (5 kHz)
	Comments	Criterion B
Surge current loads (surge)	EN 61000-4-5	
	Input	± 0.5 kV (2 Ω)
	Signal	± 2 kV (12 Ω)
	Comments	Criterion B
Conducted interference	EN 61000-4-6	
	Voltage	10 V
	Comments	Criterion A

Emitted interference in acc. with EN 61000-6-4

Interference emission	EN 55011 Class A, industrial applications
Criterion A	Normal operating behavior within the specified limits
Criterion B	Temporary impairment of operating behavior that is corrected by the device itself

5 Safety notes

**WARNING:**

Observe the following safety notes when using the device.

- Installation, operation, and maintenance may only be carried out by qualified electricians. Follow the installation instructions as described.
- When installing and operating the device, the applicable regulations and safety directives (including national safety directives), as well as general technical regulations, must be observed. The technical data is provided in the package slip and on the certificates (conformity assessment, additional approvals where applicable).
- Changing or modifying the device beyond the configuration is not permitted. Do not repair the device yourself; replace it with an equivalent device. Repairs may only be performed by the manufacturer. The manufacturer is not liable for damage resulting from noncompliance.
- The IP20 protection (IEC 60529/EN 60529) of the device is intended for use in a clean and dry environment. The device must not be subject to mechanical strain and/or thermal loads, which exceed the limits described.
- The switches of the device that can be accessed may only be actuated when the power supply to the device is disconnected.
- The device is designed exclusively for SELV operation according to IEC 60950/EN 60950/VDE 0805. The device may only be connected to devices, which meet the requirements of EN 60950.

5.1 UL Notes

PROCESS CONTROL EQUIPMENT FOR HAZARDOUS LOCATIONS 31ZN

- A) All wiring of these devices must be in accordance with the national electric code article 501.4(B) for Class 1, Division 2.
- B) Product must be installed in Class I, Zone 2 certified at least an IP54 enclosure.
- C) Product must be used in no more than a pollution degree 2 environment as defined by IEC 60664-1
- D) Provisions must be made to provide transient protection to the product so that voltage levels do not exceed 40% of the rated voltage at the power supply terminals.

Wire Range: 30-12 AWG,

Torque: 5-7 Lbs-In

Supply voltage range 24 V DC $\pm 20\%$ $\bar{\text{---}}$ 85 mA

6 Application examples

The RS-232 interface is an asymmetric voltage interface with common signal ground for all signals. In addition to its very low signal power, a characteristic feature of the interface is that the signal ground is connected to the grounded chassis housing. This results in very little immunity to interference and a maximum range of 15 meters. Considerably higher immunity to interference is achieved in industrial applications with the interface converter for electrical isolation.

Interference-free RS-232 interface

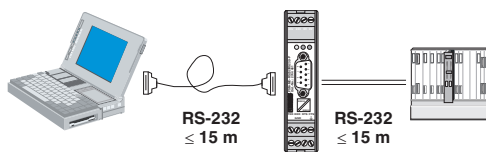

Figure 1 Interference-free RS-232 interface

With their high-grade 3-way isolation between both interface sides the devices provide a floating and interference-resistant RS-232 interface for the supply and ground potential.

Expensive termination devices are protected against damage by this decoupling.

Electrical isolation

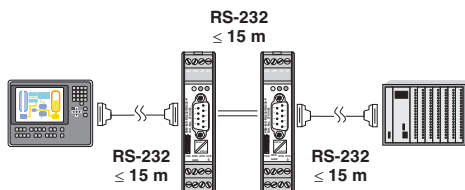

Figure 2 Electrical isolation

Any potential references can be removed from the transmission path by using additional isolator modules on both device interfaces.

7 Structure

7.1 Dimensions

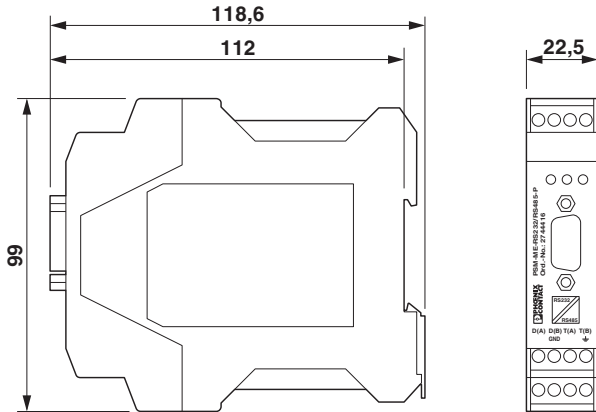

Figure 3 Housing dimensions

7.2 Block diagram

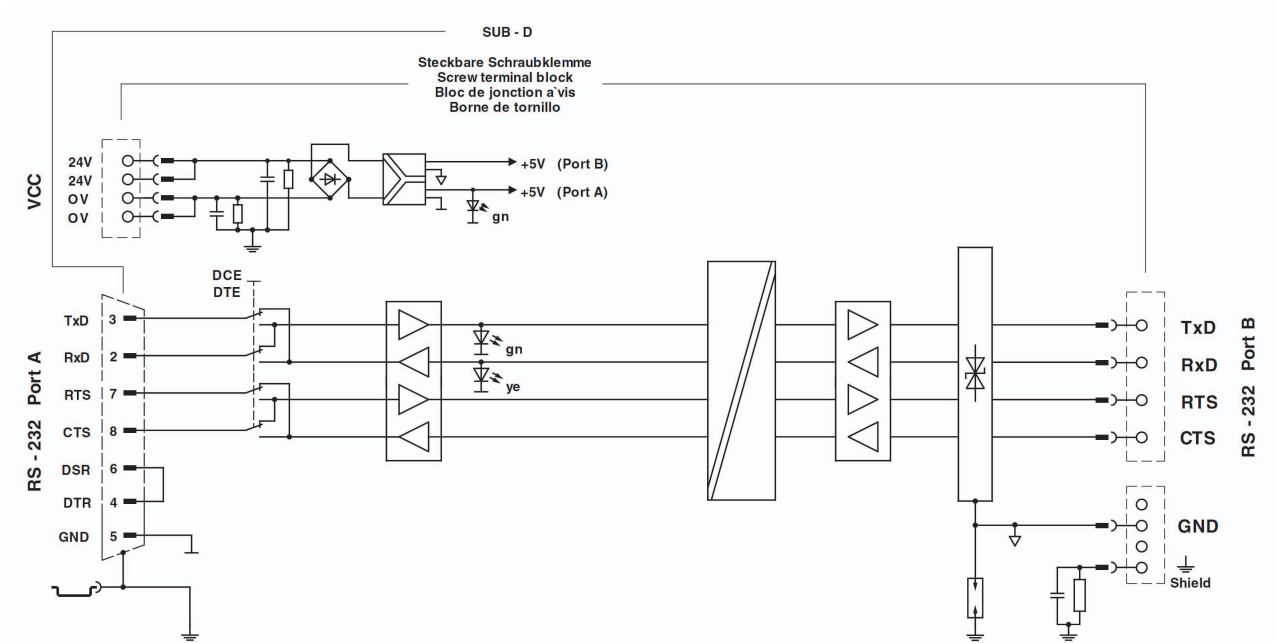

Figure 4 Block diagram

7.3 Function elements

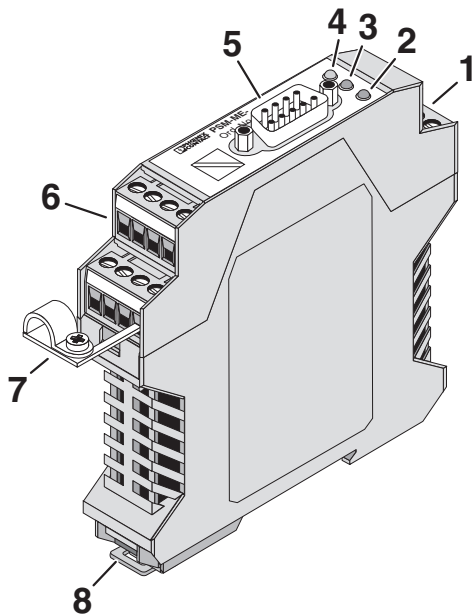

Figure 5 Function elements

COMBICON plug-in screw terminal blocks

- 1 Supply voltage
- 6 RS-232 (B) RS-232 interface

Operating elements

- 5 RS-232 (A) D-SUB 9-pos. (pin) RS-232 interface
- 7 Shield connection clip
- 8 Locking latch for DIN rail mounting

Diagnostics and status indicators

- 2 VCC (green) Supply voltage
- 3 RD (green) RS-232 (A) Receive data, dynamic
- 4 TD (yellow) RS-232 (A) Transmit data, dynamic

8 RS-232 interface

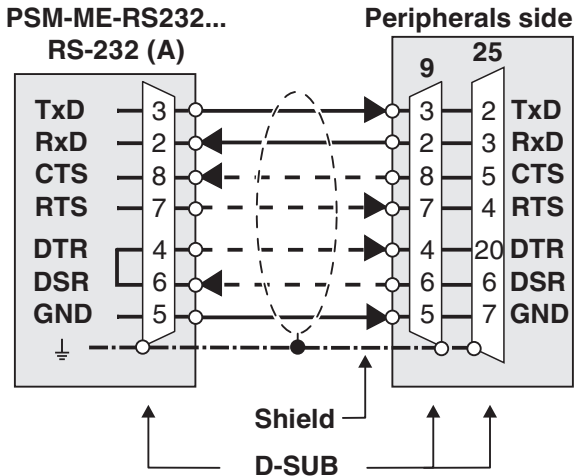

Figure 6 RS-232 interface (A)

Pin	D-SUB 9 (A)	Designation
3	TxD	Transmit data
2	RxD	Receive data
8	CTS	Clear to send
7	RTS	Request to send
5	GND	Operating ground
4	DTR	DTE ready
6	DSR	Ready to operate
Shield	⊥	Shield connection

Create a 1:1 connection between the PSM module's RS-232 interface and the peripheral.

Note: The minimum configuration only requires one connection for Tx, Rx and GND (software handshake)!

- Plug the 9-pos. D-SUB connector onto the device.

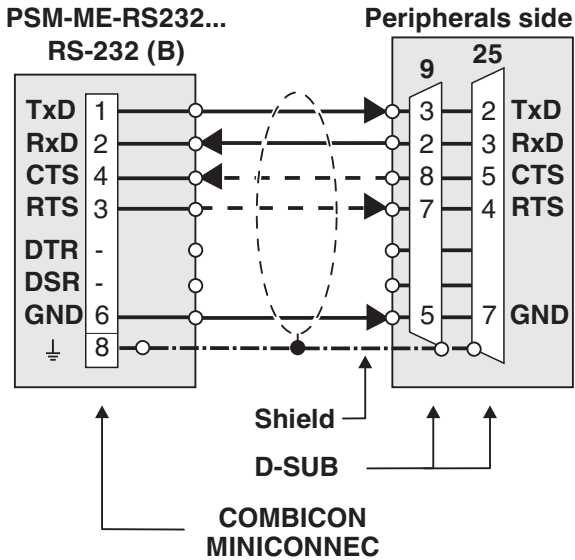

Figure 7 RS-232 interface (B)

8.1 DTE/DCE adjustment

The TxD and RxD as well as the RTS and CTS cables can be crossed internally using a DTE/DCE slide switch so that you are able to conveniently adapt to DTE or DCE interfaces.

You must open the housing to access the slide switch.



NOTE: electrostatic discharge!

The device contains components that can be damaged or destroyed by electrostatic discharge. When handling the device, observe the necessary safety precautions against electrostatic discharge (ESD) according to EN 61340-5-1 and IEC 61340-5-1.

- Disengage the housing cover with a screwdriver (A).
- Carefully pull the PCB out of the housing as far as possible.

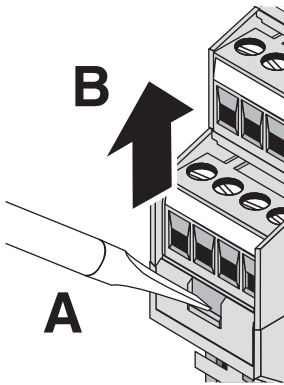

Figure 8 Opening the housing

DTE/DCE

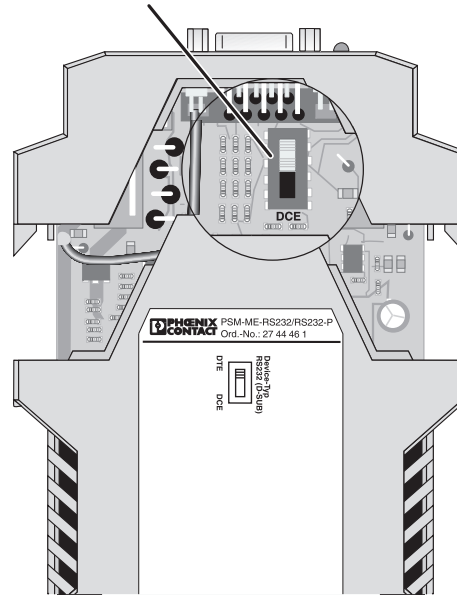

Figure 9 Remove the PCB

When connecting to a DTE device (Data Terminal Equipment), slide the switch to the DTE position.

When connecting to a DCE device (Data Communication Equipment) slide the switch to the DCE position.



If the connected interface type is not known, you can determine the right configuration by **testing** the S1 DTE /DCE-slide switch.

The DSR/DTR control lines are permanently bridged internally!

8.2 COMBICON pin assignment

Pin	COMBICON (B)	Designation
1	TxD	Transmit data
2	RxD	Receive data
3	RTS	Request to send
4	CTS	Clear to send
6	GND	Operating ground
8	⏚	Shield connection

Interface adaptation

On the field side, you can adapt the interface converter to DTE or DCE devices at the COMBICON plug-in screw terminal blocks.

DTE

- When connecting to a DTE device (standard for the majority of applications), cross the TXD/RXD and RTS/CTS cables.

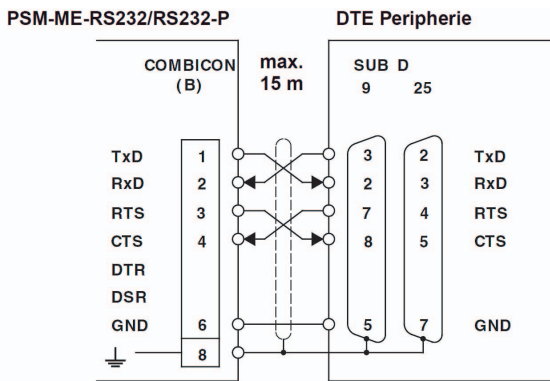

Figure 10 Connection to a DTE device

DCE

- When connecting to a DCE device, connect the devices 1:1.

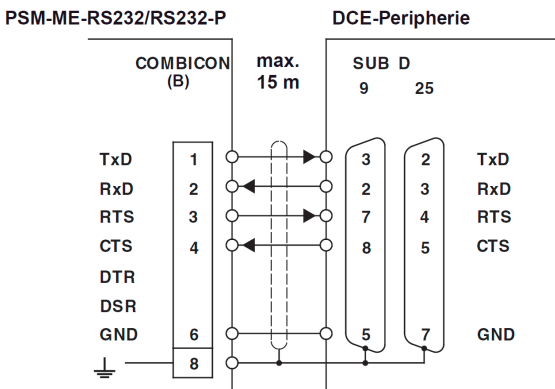

Figure 11 Connection to a DCE device



If you do not know which type of interface is connected, you can determine the right configuration by **trial and error**.

You can use the diagnostic LEDs to track the communication setup. The indicators always relate to the data traffic at the D-SUB interface.

8.3 Connecting the data cables



NOTE: Interference

Use shielded twisted pair data cables. Connect the cable shielding at both ends of the transmission path.

- For the shield connection, use the provided shield connection clip.

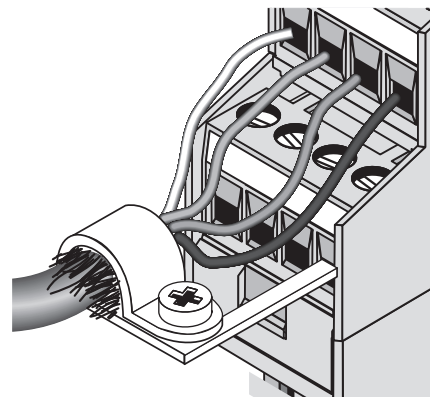

Figure 12 Install shield clip

9 Assembly



CAUTION: Electric shock

The device is only intended for operation with SELV according to IEC 60950/EN 60950/VDE 0805.



NOTE: Malfunction

Connect the DIN rail to protective earth ground using a grounding terminal block. The device is grounded when it is snapped onto the DIN rail.

This ensures the integrated surge protection is functional and that the shielding of the data cable is effective.

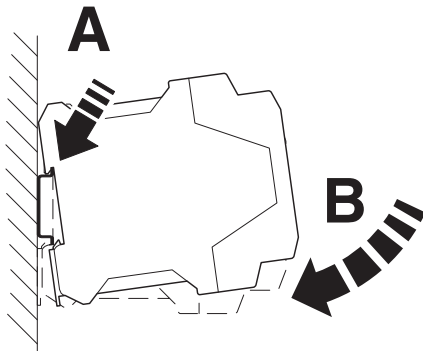

Figure 13 Mounting on a DIN rail

- To avoid contact resistance, only use clean, corrosion-free 35 mm DIN rails according to DIN EN 60715.
- Install an end bracket next to the left-hand device to prevent the devices from slipping.
- Place the device onto the DIN rail from above. Push the module from the front toward the mounting surface until it audibly engages.

9.1 Removal

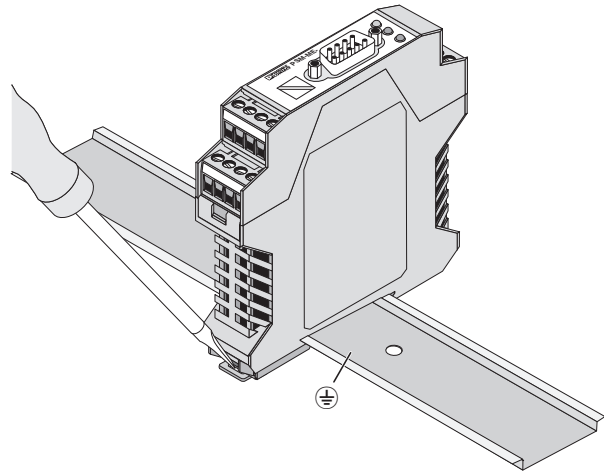

Figure 14 Removal

- Push down the locking tab with a screwdriver, needle-nose pliers or similar.
- Slightly pull the bottom edge of the device away from the mounting surface.
- Pull the device away from the DIN rail.

9.2 Power supply

The device is supplied with 24 V DC or AC.

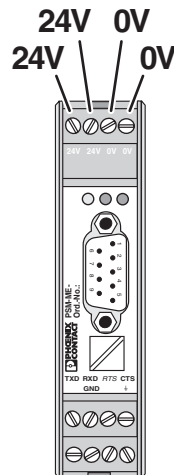

Figure 15 Power supply

- Provide supply voltage to the device via terminal 1 (pin 1 and pin 3).