

## 6 | Troubleshooting

### Connecting a Signal Ground

(common, reference) on the RS-422/485 side.

The specifications for most RS-422 and RS-485 devices indicate that the device can withstand a maximum VCM of -7 Volts to +12Volts. The function of the GND connection is to tie the signal grounds of all nodes on a network to one common ground potential. This ensures that the common mode voltage cannot exceed the specified value.

A signal ground is required on Model 485DRCI-PH because it is an optically isolated device. If you do not have a signal ground (common, reference) on your RS-422/485 device, you can connect to the DC power ground of your RS422/485 device.

*Caution: Make sure that this is connected correctly.*

*Note: Do Not use the shield drain wire as the signal ground between RS-422/485 devices.*

## 7 | UL Class 1/Div. 2 Information

SUITABLE FOR USE IN CLASS I, DIVISION 2, GROUPS A, B, C AND D HAZARDOUS LOCATIONS, OR NONHAZARDOUS LOCATIONS ONLY.

CONVENANT À L'EMPLOI DANS LES SITES DANGEREUX DE CLASSE I, DIVISION 2, GROUPE A, B, C ET D, OU DANS LES SITES NON HASARDEUX SEULEMENT.

WARNING - EXPLOSION HAZARD - SUBSTITUTION OF ANY COMPONENT MAY IMPAIR SUITABILITY FOR CLASS I, DIVISION 2.

ATTENTION - DANGER D'EXPLOSION - LA SUBSTITUTION DE COMPOSANTS PEUT ENTRAÎNER UNE ADÉQUATION À LA CLASSE I, DIVISION 2.

WARNING - EXPLOSION HAZARD - DO NOT DISCONNECT EQUIPMENT WHILE THE CIRCUIT IS LIVE OR UNLESS THE AREA IS KNOWN TO BE FREE OF IGNITABLE CONCENTRATIONS.

ATTENTION - DANGER D'EXPLOSION - LA SUBSTITUTION DE COMPOSANTS PEUT ENTRAÎNER UNE ADÉQUATION À LA CLASSE I, DIVISION 2.

Field wiring connections must be made using 105 °C minimum copper supply wires.

Les connexions de câblage sur site doivent être réalisées en utilisant des câbles d'alimentation en cuivre de 105 °C minimum.

To be installed in accordance with control drawing 8512r001.  
Pour être installé conformément au dessin de contrôle 8512r001.

### Recommended Accessories

**Power Supply**  
Model# MDR-20-24



**DIN RAIL ADAPTER**  
Model# DRAD35



**B+B SMARTWORX**

Powered by

**ADVANTECH**

1 (888) 948-2248 | Europe: +353 91 792444

[advantech-bb.com](http://advantech-bb.com)

707 Dayton Road | PO Box 1040 | Ottawa, IL 61350

Phone: (815) 433-5100 | Fax: (815) 433-5109

[www.advantech-bb.com](http://www.advantech-bb.com) | E-mail: [support@advantech-bb.com](mailto:support@advantech-bb.com)

# QUICK START GUIDE



## Model 485DRCI-PH

3-Way Isolated RS-232 to  
RS-422/485 Converter

Before you begin, be  
sure you have the following:

+ 485DRCI-PH Converter

+ 10 to 48VDC Power Supply

**B+B SMARTWORX**

Powered by

**ADVANTECH**

# 1 Product Overview

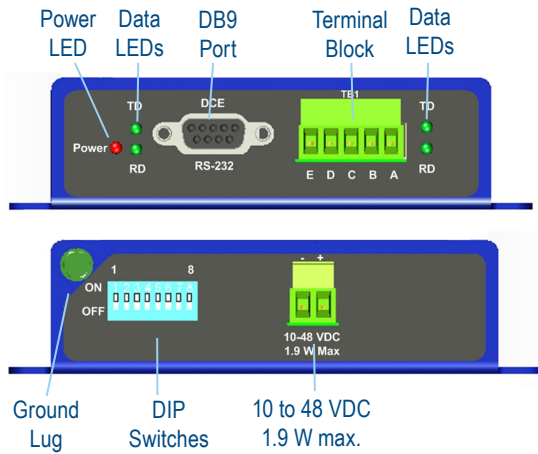

+ Grounding the unit is recommended. Connect a grounding wire from the ground lug to a good source of Earth Ground.

BUILT-IN TRANSMIT BIAS RESISTOR	SWITCH
	6
Use External or No Bias Resistor	ON
Use Built-in 1.2KΩ Transmit Bias Resistor	OFF

BUILT-IN RECEIVE BIAS RESISTOR	SWITCH
	7
Use External or No Bias Resistor	ON
Use Built-in 1.2KΩ Receive Bias Resistor	OFF

+ Switch position 8 is not used.

For an explanation of RS-485 termination and biasing requirements, refer to B+B SmartWorx' RS-422/485 Application Note. This publication can be downloaded at: [www.advantech-bb.com](http://www.advantech-bb.com)

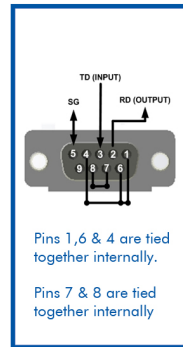

PIN	SIGNAL	DIRECTION
1	DCD	***
2	RD	OUTPUT
3	TD	INPUT
4	DTR	***
5	GND	***
6	DSR	***
7	RTS	***
8	CTS	***
9	RI	***

DB9 Pinouts

DIP SWITCH RS-422/485 4-WIRE						
1	2	3	4	5	6	7
ON/OFF	OFF	OFF	OFF	***	***	***

Position 1 = ON for RS-485, OFF for RS-422.  
Positions 5, 6, 7 are used for termination and biasing.

DIP SWITCH RS-485 2-WIRE						
1	2	3	4	5	6	7
ON	ON	ON	ON	x	x	x

Positions 5, 6, 7 are used for termination and biasing.

# 2 Set the DIP Switches

COMMUNICATIONS MODE				
Switch	1	2	3	4
RS-485 2-Wire Half-Duplex	ON	ON	ON	ON
RS-485 4-Wire Full-Duplex	ON	OFF	OFF	OFF
RS-422 Full-Duplex	OFF	OFF	OFF	OFF

BUILT-IN TERMINATION RESISTOR	SWITCH
	5
Use Built-in 120Ω Termination	ON
Use External or No Termination	OFF

# 3 Wire the Converter

TERMINAL	RS-485 2-WIRE	RS-422/485 4-WIRE
A	***	TDA (-)
B	***	TDB (+)
C	Data A (-)	RDA (-)
D	Data B (+)	RDB (+)
E	GND	GND

# 5 Check LEDs

LEDs	
Power LED	Red = ON when power is applied.
Data LEDs	Green = LEDs flash when data is present on the port.

# 4 Loopback Test

- Configure for RS-485 Four-Wire.
- Jumper terminals A to C and B to D.
- Connect a PC to the RS-232 port (see Step 3).
- Using HyperTerminal or a similar program, connect to the appropriate COM port.
- Turn off HyperTerminal local Echo.
- Transmit data. The same data should be returned. When data is sent and looped back, the TD and RD LEDs will blink on both ports.