

6 | Troubleshooting

What baud rates can be used?

Baud rates up to 921 Kbps.

What operating systems are supported?

Windows 2000, XP, Vista 32/64 bit, 7 32/64 bit, 8 32/64, 10 32/64 bit.

Which USB cables can I use?

A one meter (3 ft) cable is included. Other lengths can be purchased separately. The maximum range for USB is 4.5 meters (15 ft). B+B SmartWorx sells USB extenders if you need to go farther than 4.5 meters (15 ft).

Can I get a version with a terminal block instead of the DB9?

Yes. The model part number is USOPTL4.

How can I test the USO9ML4 to make sure it is working correctly?

Do a loopback test. A quick way to test is to set the dip switches to 485, Echo ON, 2-wire, 2-wire. Then, use HyperTerminal to do the loopback. Visit the B+B SmartWorx technical library for instructions and screen shots.

Recommended Accessories

4 Port Powered USB Hub

Model# UHR304



B+B SMARTWORX

Powered by

ADVANTECH

1 (888) 948-2248 | Europe: +353 91 792444

advantech-bb.com

707 Dayton Road | PO Box 1040 | Ottawa, IL 61350

Phone: (815) 433-5100 | Fax: (815) 433-5109

www.advantech-bb.com | E-mail: support@advantech-bb.com

Documentation Number: 710-10918-00_r1_USO9ML4_2118qsg

+ QUICK START GUIDE



Model USO9ML4

Isolated USB to RS-422/485 Converter

Before you begin, be sure you have the following:

- + USO9ML4 Converter
- + USB Cable

B+B SMARTWORX

Powered by

ADVANTECH

Fast and easy on the web: www.advantech-bb.com

Product Overview

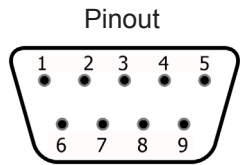

Pin	Description
1	*****
2	RDA (-)
3	TDB (+)
4	GND
5	*****
6	GND
7	RDB(+)
8	TDA (-)

2 | Set DIP Switches

OFF = left ON = right

DIP Switch Position		
Switch	OFF	ON
1	TD always enabled (TD 422)	TD only enabled during data transmission (TD 485)
2	RD always enabled (ECHO ON)	RD disabled during data transmission (ECHO OFF)
3	4-wire mode (4-Wire)	2-wire mode (2-Wire)
4	4-wire mode (4-Wire)	2-wire mode (2-Wire)

4-Wire RS-422/485

- RS-422 = All DIP Switches OFF
- RS-485 = DIP SW 1 ON, DIP SWs 2, 3 and 4 OFF

4 Wire Set-up

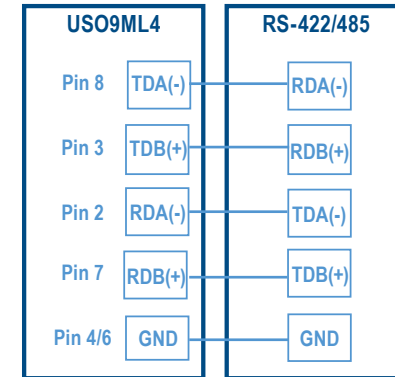

1 | Install Drivers

Your system will detect the USO9ML4 when you plug it in. If you are attached to the Internet, you can get the drivers via Windows Update. This may take a few minutes.

You can download the drivers directly from the B+B SmartWorx website.

Note: Vista users should use an account with administrative rights.

After connecting the device you can check Device Manager to learn which COM port number was assigned (Control Panel/System/Hardware/Device Manager/Ports/COM & LPT).

You can re-assign COM numbers by clicking the Advanced Settings button on the Port Settings screen.

3 | Wire the Converter

2-Wire RS-485

- All DIP Switches = ON

2-Wire Set-up

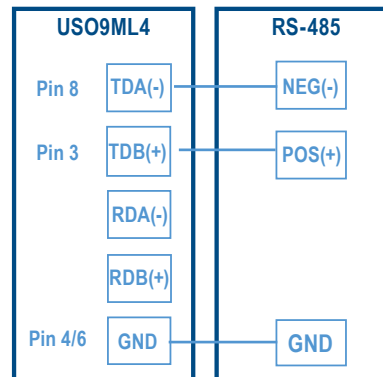

4 | Loopback Test

Set DIP switches to RS-485, Echo ON, 2-Wire, 2-Wire.

Use HyperTerminal or another terminal program to confirm passage of data through the converter.

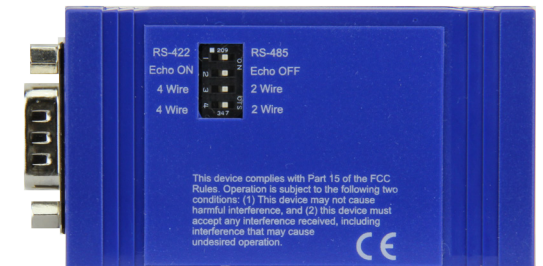

5 | Check LEDs

When everything is installed and connected, the LEDs will blink to indicate that data traffic is passing through the converter.