



Digi Connect[®] Sensor

I/O Wiring Guide

Revision history—90001493

Revision	Date	Description
A	May 2016	Initial release.
B	October 2016	<ul style="list-style-type: none">■ Added C1D2 certification information.■ Added wiring compliance information.
C	March 2017	<ul style="list-style-type: none">■ Added HART® protocol information.■ Added Serial Power section for use with Modbus.■ Updated 4/20mA current loop section.
D	April 2017	<ul style="list-style-type: none">■ Added registered trademark symbol to HART®.

Trademarks and copyright

Digi, Digi International, and the Digi logo are trademarks or registered trademarks in the United States and other countries worldwide. All other trademarks mentioned in this document are the property of their respective owners.

© 2017 Digi International Inc. All rights reserved.

Disclaimers

Information in this document is subject to change without notice and does not represent a commitment on the part of Digi International. Digi provides this document “as is,” without warranty of any kind, expressed or implied, including, but not limited to, the implied warranties of fitness or merchantability for a particular purpose. Digi may make improvements and/or changes in this manual or in the product(s) and/or the program(s) described in this manual at any time.

Warranty

To view product warranty information, go to the following website:

www.digi.com/howtobuy/terms

Send comments

Documentation feedback: To provide feedback on this document, send your comments to techcomm@digi.com.

Customer support

Digi Technical Support: Digi offers multiple technical support plans and service packages to help our customers get the most out of their Digi product. For information on Technical Support plans and pricing, contact us at +1 952.912.3444 or visit us at www.digi.com/support.

Contents

About Digi Connect® Sensor

Connect Sensor hardware replacement	5
Digi Device Cloud and Digi Remote Manager	5

About the Connect Sensor I/O interface

Safety notices and certifications	6
CSENSE Continuous Monitoring firmware	6
Using a Modbus-enabled device	6

I/O interface pin assignments

9-pin connector details	7
12-pin connector details	8

Wire sensors to the I/O interface

Power options

Power the Connect Sensor	14
Power the sensors	14

Analog input

Voltage input	16
Self-powered	16
3-wire sensors	16
Current loop	16
Self-powered	17
2-wire (loop-powered) sensors	17
3-wire sensors	18

Digital I/O

Digital input and pulse counter	20
Digital output	21

Modbus serial power output

I/O schematics

Analog input schematic	24
------------------------------	----

Digital I/O schematic25

About Digi Connect® Sensor

Connect Sensor is a low-power cellular sensor gateway for wireless drop-in networking to remotely monitor industrial environments and control systems, such as pipeline flow, air pressure, and light levels. To power Connect Sensor, use either the internal battery or an external power source, such as solar panels, for setups with no power or limited power.

Connect Sensor includes an external input/output (I/O) interface inside a waterproof enclosure for connecting third-party sensors. The sensors gather information (sensor readings) from their environment, and Connect Sensor reports that information to Digi Remote Manager® using a low-bandwidth cellular connection. You can sign in to your Remote Manager account to view the reports or use the Digi Connect Wizard app on a mobile device and pair it with a nearby Connect Sensor to view real-time sensor and device data in the field.

Note Make sure there is adequate cellular network coverage where you plan to install the gateway before purchasing cellular service.

This guide shows you how to wire analog or digital I/O sensors and power to Connect Sensor. See the [Digi Connect Sensor User Guide](#) for details about setting up the Connect Sensor device, configuring sensors and reports, and viewing sensor data.

Connect Sensor hardware replacement

The Connect Sensor hardware can be replaced with Connect Sensor+ hardware, which provides additional external device monitoring features, such as using the HART® protocol and the Modbus protocol.

Digi Device Cloud and Digi Remote Manager

Note To serve our customers most effectively, Digi International Inc. is consolidating its cloud services, Digi Device Cloud and Digi Remote Manager®, under the Remote Manager name. This phased process does not affect device functionality or the functionality of the web services and other features. However, you will find instances of both Device Cloud and Digi Remote Manager in some documentation, firmware, and user interfaces.

About the Connect Sensor I/O interface

You can wire analog and digital inputs and outputs on the Connect Sensor general purpose I/O interface.

Note If you are using a Modbus-enabled external sensor device, you must wire the sensor device to a serial output. Note that the Modbus protocol is available only with Connect Sensor+.

Make sure Connect Sensor has cellular connectivity before wiring sensors to the I/O interface. After setting up Connect Sensor and wiring the I/O interface, use Remote Manager to remotely configure I/O settings.

Safety notices and certifications

Digi products are designed to the highest standards of safety and international standards compliance for the markets in which they are sold. However, cellular-based products contain radio devices that require specific consideration. Make sure you read and understand all of the safety notices, warnings, and cautions for this product. Digi International assumes no liability for failure to comply with the safety precautions.

See the [Connect Sensor User Guide](#) for details about safety and certification for Connect Sensor.

CSENSE Continuous Monitoring firmware

When you update Connect Sensor with the CSENSE Continuous Monitoring firmware option, Connect Sensor supports only one power output (A1Pwr), which is on all the time. Multiple sensors can share this supply, but all sensors must have the same input voltage and must be wired to A1Pwr.

Using a Modbus-enabled device

If you have a Modbus-enabled device that must get power from Connect Sensor, the Modbus device must be wired to the serial power output. However, if you have updated Connect Sensor with the CSENSE Continuous Monitoring firmware option, the Modbus device must be wired to A1Pwr (analog interface 1 power output). The Modbus device must have the same input voltage as any other device wired to A1Pwr.

Note The Modbus protocol is available only with Connect Sensor+ hardware.

I/O interface pin assignments

Connect Sensor has two I/O connectors—a 9-pin connector and a 12-pin connector.

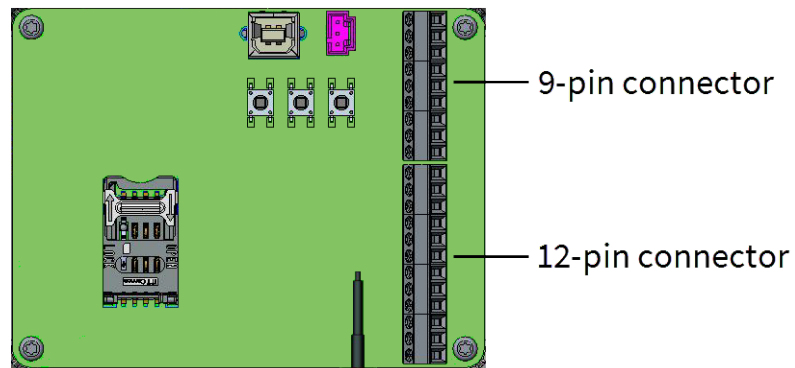

The pin assignments and signals are shown in the following images and tables.

9-pin connector details

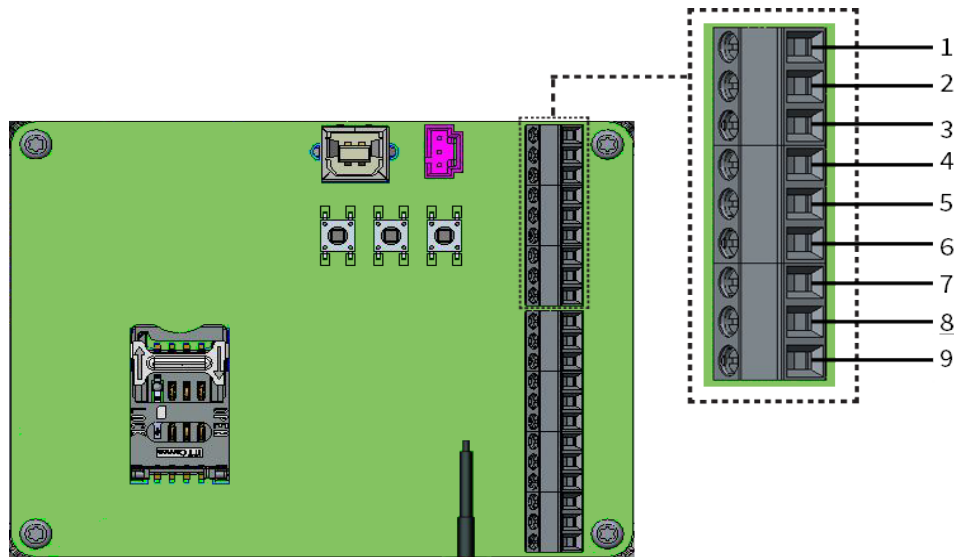

Pin number	Assignment	Signal
1	SGnd	Serial interface ground
2	SRX/-	Serial interface Modbus -
3	STX/+	Serial interface Modbus +
4	SPwr	Serial interface power output
5	EXT GND IN	External power supply, ground
6	EXT PWR IN	External power supply, positive input
7	DGnd	Digital interface, ground
8	DIO	Digital interface I/O
9	DPwr	Digital interface power output

12-pin connector details

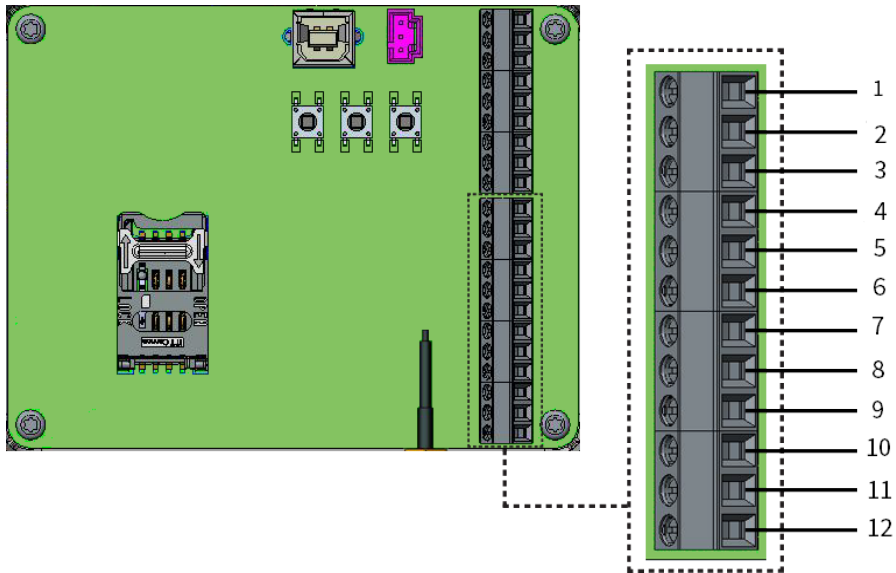

Pin number	Assignment	Signal
1	A 4 GND	Analog interface 4, ground
2	A 4 IN	Analog interface 4, analog input
3	A 4 Pwr	Analog interface 4, power output
4	A 3 GND	Analog interface 3, ground
5	A 3 IN	Analog interface 3, analog input
6	A 3 Pwr	Analog interface 3, power output

Pin number	Assignment	Signal
7	A 2 GND	Analog interface 2, ground
8	A 2 IN	Analog interface 2, analog input
9	A 2 Pwr	Analog interface 2, power output
10	A 1 GND	Analog interface 1, ground
11	A 1 IN	Analog interface 1, analog input
12	A 1 Pwr	Analog interface 1, power output

Wire sensors to the I/O interface

To wire third-party sensors to the Connect Sensor I/O interface, you need the following equipment:

- A slot-headed 0.4 x 2.5 x 80 mm screwdriver
- Wire size 1.29-0.25 mm (16-30 AWG) for each pin connector

Note All external or field wiring must be in accordance with NFPA 70 Article 501.10(B).

To wire sensors to the I/O interface:

1. Open the Connect Sensor enclosure and disconnect all power sources.



CAUTION! You must disconnect power from Connect Sensor before wiring sensors to the I/O interface.

2. Unscrew the gland cap and remove the plastic seal.

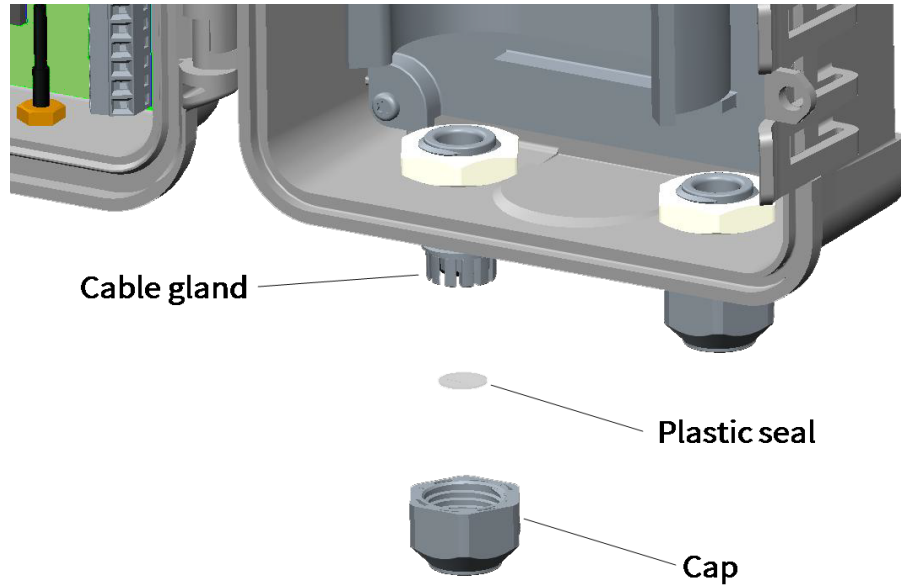

Note For an unused cable gland, make sure the plastic hole cover stays in place to keep it sealed. Over tightening an unused cable gland cap can force out the plastic hole cover, unsealing the cable gland.

3. Run the sensor cable through the cap and thread it through the cable gland.

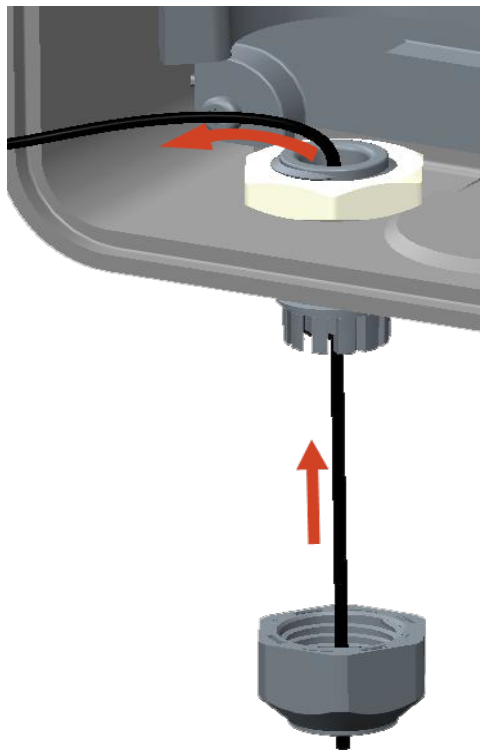

Wire sensors to the I/O interface

4. Use the screwdriver to loosen the I/O interface connector screw.
5. Slide the wire into the terminal side of the connector.
6. Tighten the screw to 0.2N-m to secure the wire to the connector.

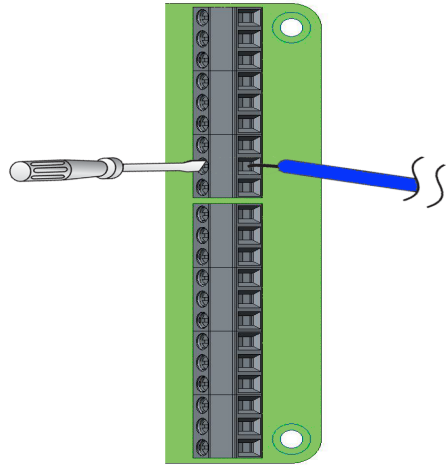

7. Tighten the cap to the cable gland to seal and secure the wire.

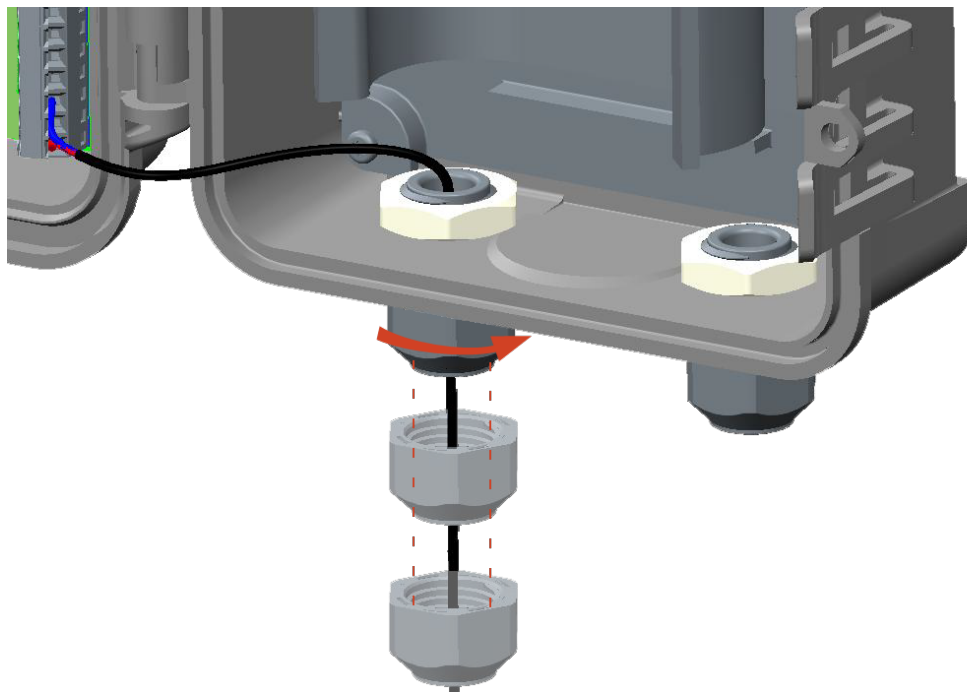

Power options

The following sections provide details about powering Connect Sensor and its sensors.

Power the Connect Sensor	14
Power the sensors	14

Power the Connect Sensor

While Connect Sensor has an internal battery for power, you can use an external power source, such as solar panels or other DC sources. For an external power source, use the **external power input** to power the Connect Sensor device.

Note the following:

- When Connect Sensor is connected to an external power source, the external power source becomes the primary power source and the internal battery becomes a backup power source. If the external power source is unable to power Connect Sensor (such as when it has an unacceptable voltage range), it automatically switches to the internal battery as the power source.
- The external power inputs accept a DC range of 8-30 V DC.

Power the sensors

The Connect Sensor can power sensors using the analog, digital, or serial power outputs. The power outputs can supply one of four output voltages to a sensor. Configure the power options in Remote Manager; see the [Connect Sensor User Guide](#).

Note If you have a Modbus-enabled device that must get power from the Connect Sensor, the Modbus device must be wired to the serial power output. For more information, see [CSENSE Continuous Monitoring firmware](#).

Note the following:

- The sensor power output voltage options are:
 - 3.3 V DC
 - 5 V DC
 - 15 V DC
 - 24 V DC
- The maximum output current for each sensor power output connector is 200 mA.

Note When using continuous monitoring, the combined maximum output current for ALL sensors is 200mA.

Analog input

The analog inputs have the following modes of operation, which are disabled by default. You can enable or disable the modes, but use only one mode for each input.

Voltage input	16
Current loop	16

Voltage input

Connect Sensor can monitor a voltage input from 0 V to 10 V. The following schematics show wiring options for 0-10 V input.

Self-powered

This figure shows the schematic when the external sensor is self-powered or powered from a source other than Connect Sensor.

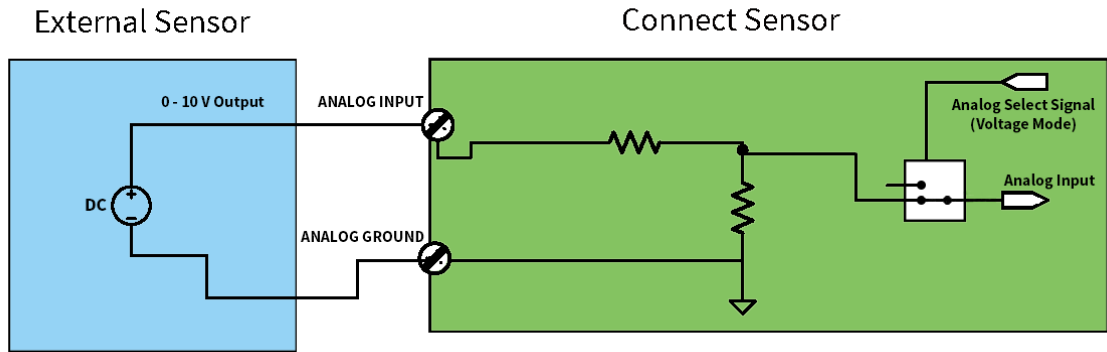

3-wire sensors

This figure shows the schematic when using power from Connect Sensor to power the sensor.

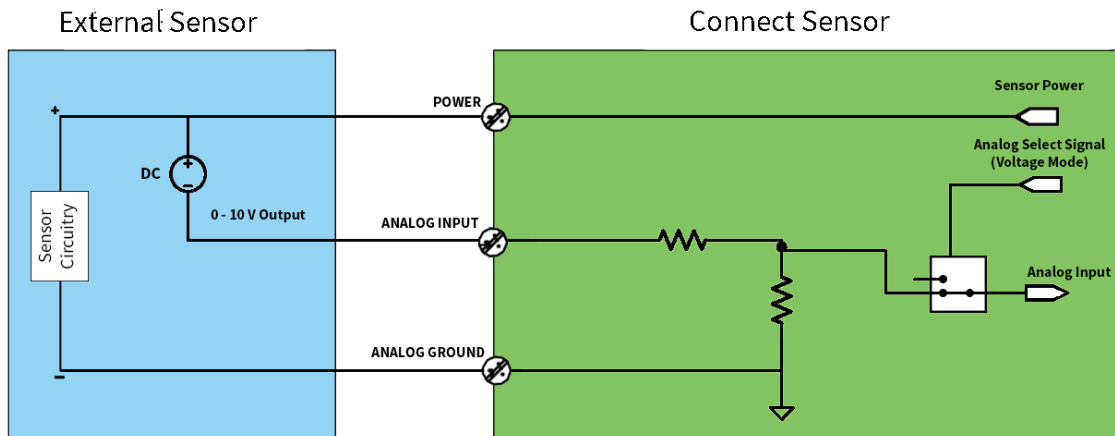

Current loop

Connect Sensor can monitor a current input from 4 mA to 20 mA. The following schematics show wiring options for 4-20 mA inputs.

Note Connect Sensor supports wired HART protocol only on analog current loop 1. Note that the HART protocol is available only with Connect Sensor+ hardware. When a sensor device that supports HART protocol is enabled on analog current loop 1, Connect Sensor reports on the HART protocol and

the current loop. If a HART sensor is connected to analog current loop 2, 3, or 4, Connect Sensor reports on the current loop only.

Self-powered

This figure shows the schematic when the external sensor is self-powered or powered from a source other than Connect Sensor.

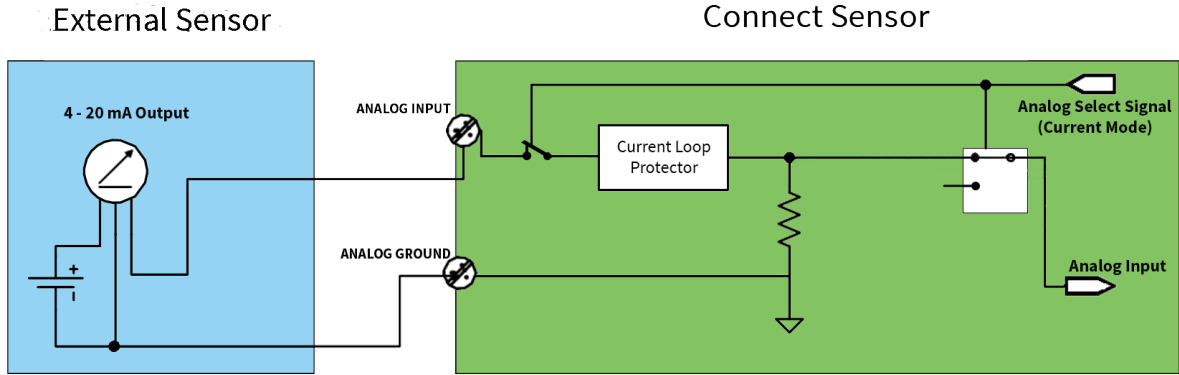

2-wire (loop-powered) sensors

You can connect Connect Sensor to a 4/20mA 2-wire sensor, which is also known as a loop-powered sensor.

This figure shows the schematic when using power from the Connect Sensor current loop to power a sensor.

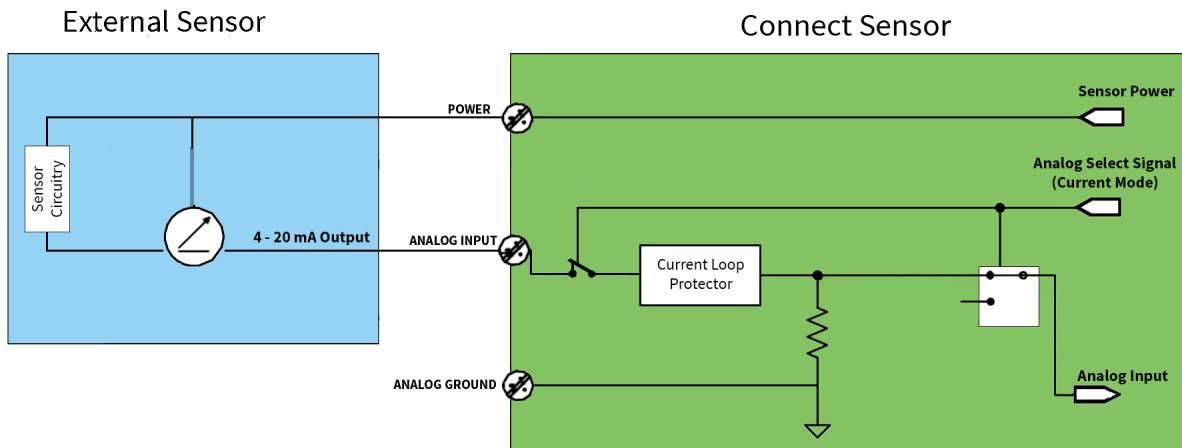

Calculating supply voltage for a 2-wire (loop-powered) sensor

The power output from Connect Sensor is configurable. The configured voltage value for Connect Sensor is between the **Power** and **Analog Ground** terminals, as shown in the schematic above. The voltage across the terminals of the external sensor device (between **Power** and **Analog Input**) fluctuates, depending on the loop current. The fluctuation occurs because the variable loop current through the resistance inside Connect Sensor changes the voltage between the **Analog Input** and **Ground** terminals. This is expected behavior for a 4/20mA 2-wire interface.

When determining the value for the output power, you must calculate the range of voltages to determine whether the voltage setting is sufficient. The voltage across the external sensor device terminals (**Power** and **Analog Input**) is always less than the configured voltage.

For example, calculate an estimate of the range of voltage across the external sensor device terminals (**Power** to **Analog Input**) when the Analog Output voltage is set to 24V. The nominal internal resistance of Connect Sensor is 375 ohms, but may vary across current flow and temperature.

- Max: $24V - (4mA * 375ohms) \approx 22.5V$
- Min: $24V - (20mA * 375ohms) \approx 16.5V$

3-wire sensors

This figure shows the schematic when the analog power output from Connect Sensor is powering the sensor.

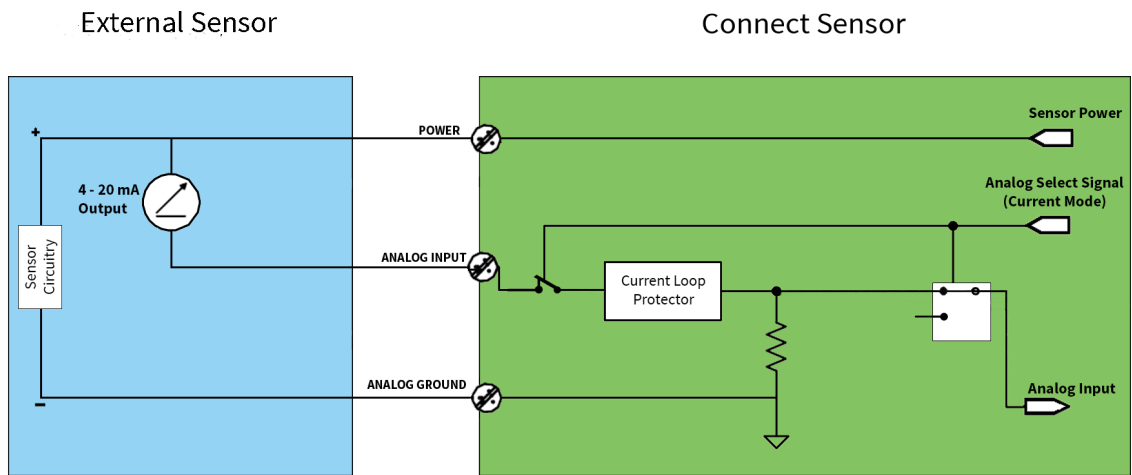

Digital I/O

Connect Sensor has one digital I/O pin. You can configure the pin as a digital input, pulse counter, or digital output, but not more than one I/O function simultaneously.

Digital input and pulse counter	20
Digital output	21

Digital input and pulse counter

When configuring the digital I/O pin as a digital input, it allows the following modes of operation:

- Input mode:** Connect Sensor gets the digital input value at scheduled sensor readings. You can configure it to send an alarm report for specific input values or when an input value changes. You can also configure Connect Sensor to wake from sleep mode when an input value changes (rising edge or falling edge wake).
- Pulse counter:** When connected to a mechanical meter, Connect Sensor counts pulses during Connect Sensor sleep cycles and reports them to Remote Manager during normal reporting intervals.

Each mode has a pull-up resistor that you can enable or disable. The pull-up indicates the digital input's state when there is no external voltage.

Note If you enable the pull-up resistor, it will constantly draw power. Depending on the current flow to the sensor, you may need to externally power Connect Sensor.

The following figure shows a digital input with the pull-up resistor enabled where it is driving an external relay.

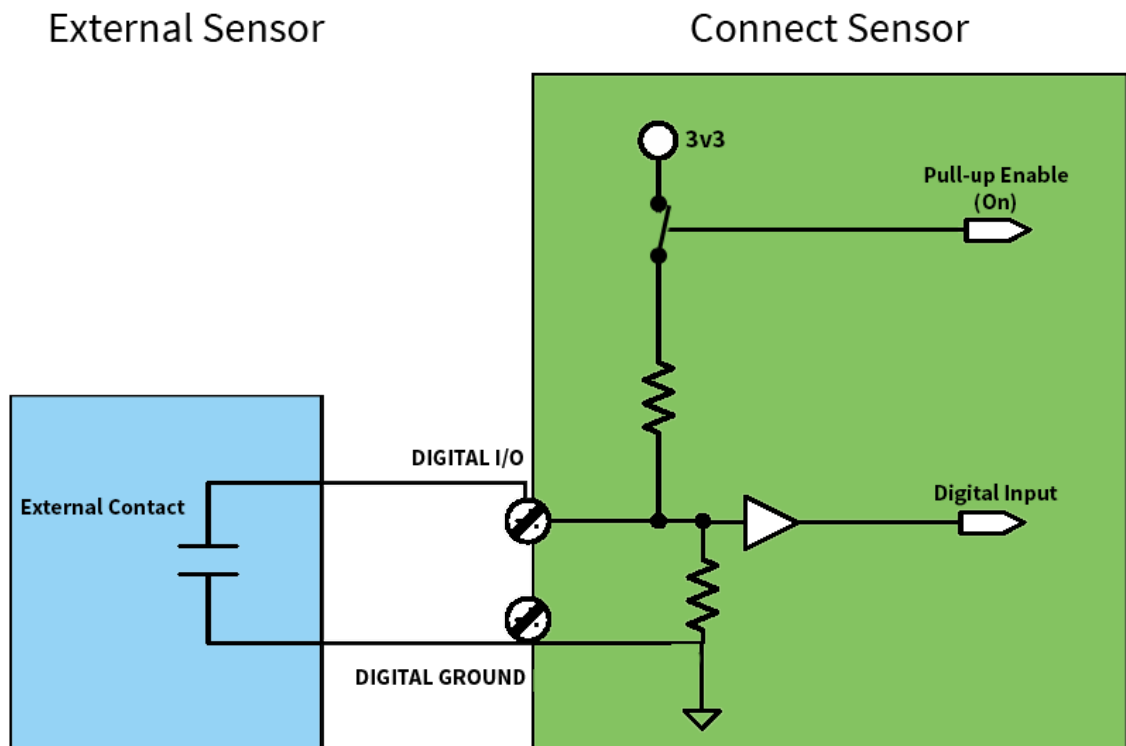

The following figure shows a digital input with the pull-up resistor disabled.

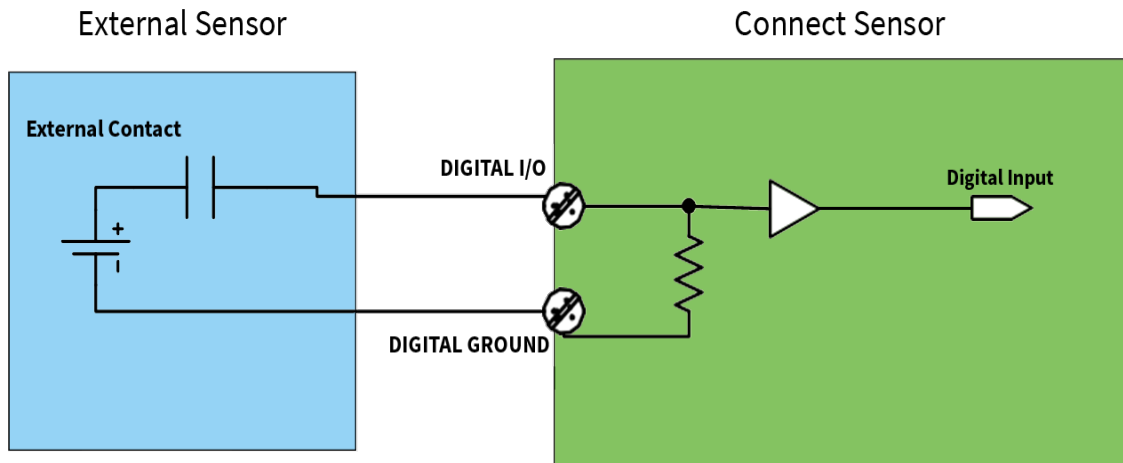

Digital output

When configuring the digital I/O pin as a digital output, it is an open collector output with an optional pull-up resistor. A self-resetting fuse limits the maximum collector current to 750 mA.

The following image shows a schematic of the typical digital-out application.

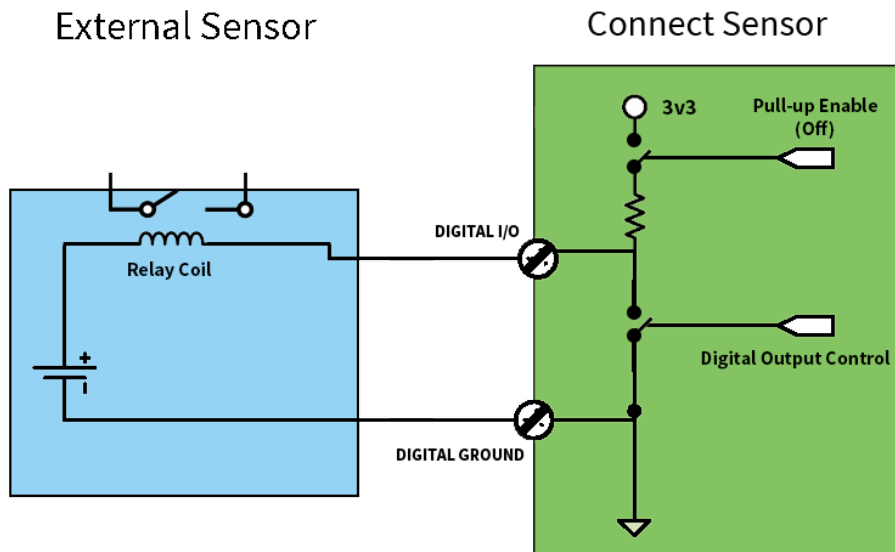

Modbus serial power output

Note The Modbus protocol is available only with Connect Sensor+ hardware.

Connect Sensor can monitor a Modbus-enabled external sensor device.

Biasing and termination are needed when a Modbus sensor is connected on a long wiring harness and the sensor does not provide its own termination and biasing. Termination is only applied at the two ends of the 485 bus (not in the middle), and bias typically is applied only once on the whole bus.

For detailed information about implementing Modbus over a serial line, refer to the Modbus documentation at www.modbus.org.

The schematic below shows how to wire the device, depending on the power source for the Modbus device: Connect Sensor or powered from a source other than Connect Sensor.

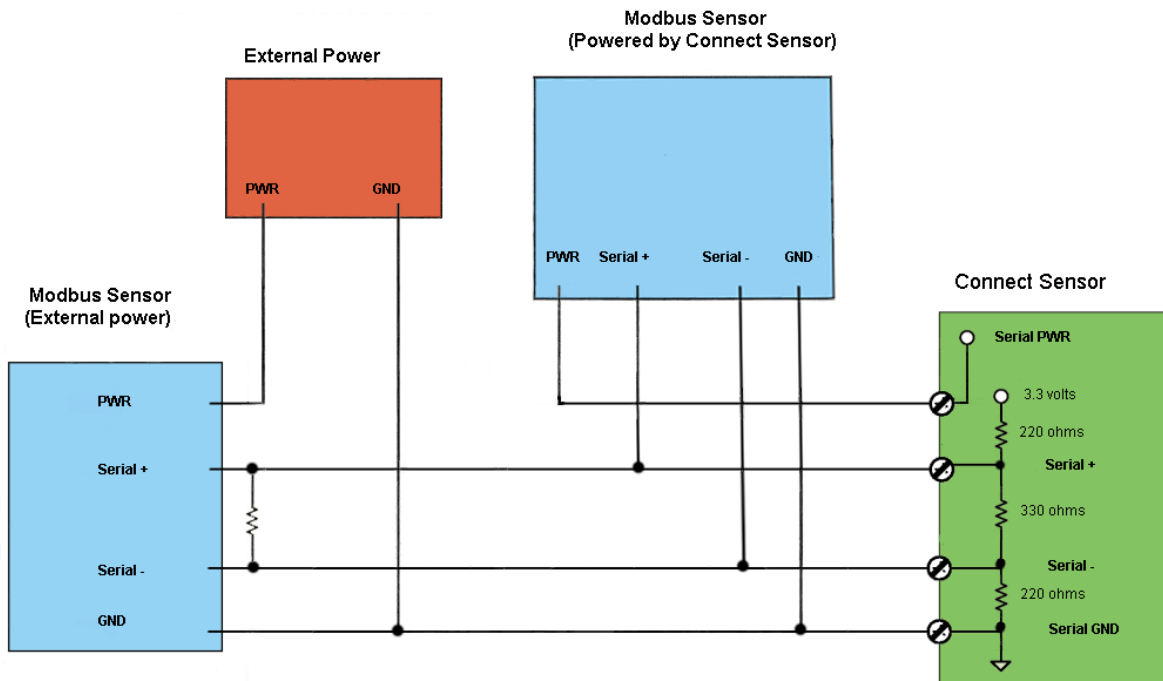

I/O schematics

The following sections show electrical wiring schematics for the Connect Sensor I/O connectors.

Analog input schematic	24
Digital I/O schematic	25

Analog input schematic

The following image is an overview of the analog input wiring diagrams.

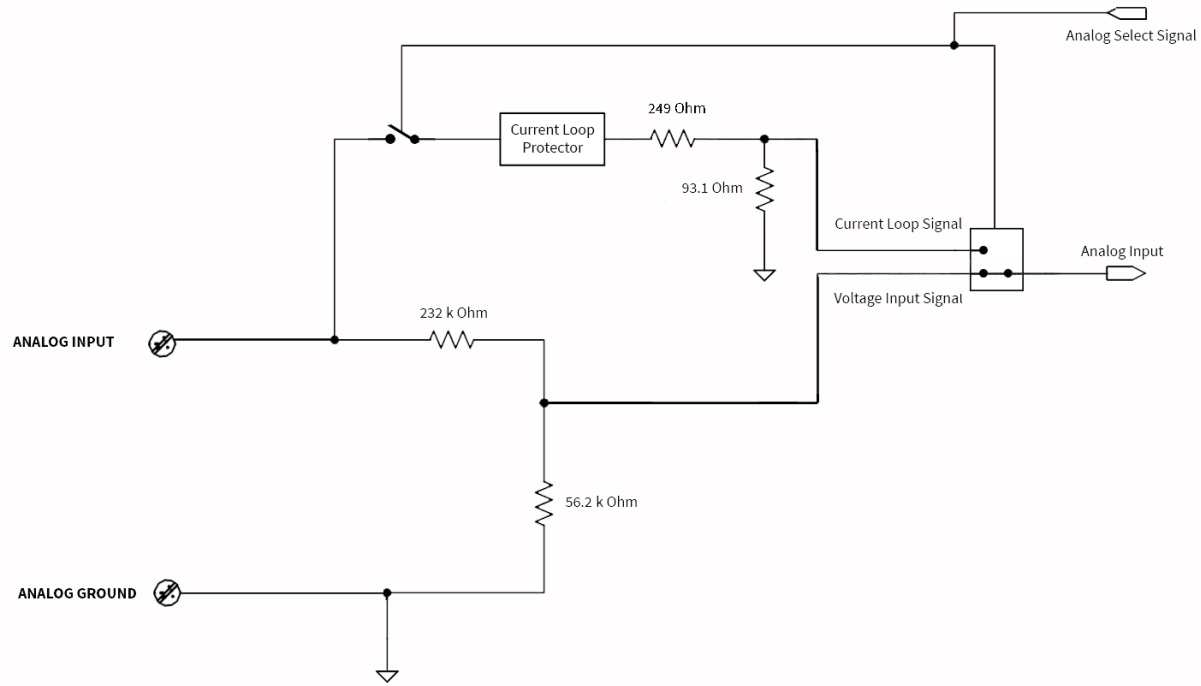

Digital I/O schematic

The following image is an overview of the digital I/O wiring diagrams.

