

IDS-206 – Managed Industrial Ethernet Switch

perle.com/products/switches/ids-206-industrial-managed-gigabit-switch.shtml



5 x 10/100/1000Base-T RJ45 and 1 x 100/1000Base-X SFP



- 5 port 10/100/1000Base-T (RJ45) for Gigabit and Fast Ethernet devices
- One 100/1000Base-X SFP fiber port (empty)
- IP Manageability, VLAN and resiliency management
- Compact, corrosion resistant case attaches to a standard DIN Rail
- Redundant dual power input 12/24/48 VDC
- Out-of-band management via RJ45
- Programmable Controller safety and Hazardous Location Certification
- -40 to 75C industrial operating temperature (XT Models)

The **IDS-206** is a **6 port Managed Ethernet Switch** that can operate in **industrial environments** providing advanced performance and enabling **real-time deterministic network operation**. Five 10/100/1000-Base-T Ethernet ports are available for networking Gigabit and Fast Ethernet devices. One 100/1000Base-X SFP fiber port allows for flexible network configurations using [SFP transceivers supplied by Perle, Cisco](#) or other manufacturers of MSA compliant SFPs.

In environments where **high levels of electromagnetic interference (EMI)** is a common phenomenon, like industrial plants, **utilizing fiber is critical**. EMI can cause data corruption over copper-based Ethernet links. Data transmitted over fiber optic cable is completely immune to this type of noise ensuring optimal data transmission across the plant floor.

Perle **Industrial-grade Ethernet Switches** are designed to stand up to **extreme temperatures, surges, vibrations**, and **shocks** found in **industrial automation, government, military, oil and gas, mining** and **outdoor applications**.

Perle's **Fast Setup feature** provides simple **Plug and Play** installation to get your Ethernet devices networked immediately. **CCNA** (Cisco Certified Network Associate) and **CCNP** (Cisco Certified Network Professional) trained engineers will appreciate the familiar **Command Line Interface (CLI)** via in-band Telnet or the out-band serial console port.

An IPv6 address can be used to manage the **IDS-206** which also supports a comprehensive set of management functions,

such as **P-Ring**, **management VLAN**, **QoS**, **RMON**, **N:1 port mirroring** and **local alert log**.

All IDS-206 models, are **rugged fan-less switches** that are hardened to provide superior reliability in **-10 to 60°C**. In addition, **every component** on every **industrial (XT) model** has been **designed and tested** to handle operating temperatures between **-40 and 75C**.

All Perle Industrial Ethernet Switches only use **high-end components** from the **leading chip manufacturers** to ensure the highest level of **durability and reliability**. In addition, all units have a corrosion resistance aluminum case and dual redundant power input with reverse polarity and overload protection.

Perle has been **designing industrial hardware** for **over 35 years**. This expertise was used to design the **toughest Ethernet switches on the market** that will keep your system running for years to come.

IDS-206 Industrial Managed DIN Rail Switch Features

Simple deployment Zero-touch discovery using Dynamic Host Control Protocol (DHCP), Perle's "Fast Setup" for first time installation, provides simple deployment in Ethernet environments.

Resiliency

- STP and RSTP protocols for fast recovery.
- Perle's **P-Ring protocol** for fast convergence in ring topologies

Manageability

- Web Device Manager, Telnet, SNMP and Perle's **PerleView** NMS for centralized management
- In-band management via RJ45 port
- Use an IPv4 or IPv6 address

Rugged design for harsh environments

- Corrosion resistant case
- Programmable Controller Safety certified
- Certified for hazardous locations
- Extended industrial temperature models

Reliable operation

- Fan-less, no moving parts
- Dual power input. Connect to separate power sources for redundancy.
 - Reverse polarity protection
 - Overload current protection
- Handles vibration and shock conditions found in industrial environments

Real-time Ethernet performance

- Fast wire-speed , store and forward switching
- Auto-sensing for speed and duplex
- Auto-mdi/mdix-crossover works with straight and crossover cables

Energy Efficient Ethernet (EEE)

Energy Efficient Ethernet (EEE) as per 802.3az provides power savings during idle network activity.

Performance Features

Port Auto-sensing

Auto-sensing of port speed and auto-negotiation of duplex on all switch ports for optimizing bandwidth

Auto MDI/MDIX

Medium-dependent interface crossover (Auto-MDIX) capability on 10/100 and 10/100/1000 mbps interfaces that enables the interface to automatically detect the required cable type (straight thru or crossover) and to configure the connection appropriately

802.3x flow control

IEEE 802.3x flow control on all ports. (The switch does not initiate pause frames)

Storm Control

Storm control prevents traffic on a LAN from being disrupted by a broadcast, multicast, or unicast storm on one of the physical interfaces. A LAN storm occurs when packets flood the LAN, creating excessive traffic and degrading network performance. Storm Control enables limits to be placed on broadcast, multicast and unicast traffic

Static MAC Addressing

This feature enables the manual configuration of the MAC addresses on a per port basis. Flooding is prevented by retaining MAC entries across a reboot of the switch.

Port Blocking

Port Blocking provides the ability to block the flooding of unknown layer 2 unicast and multicast traffic on an Interface

IPV4 IGMP Snooping

Internet Group Management Protocol (IGMP) constrains the flooding of multicast traffic by dynamically configuring Layer 2 interfaces so that multicast traffic is forwarded to only those interfaces associated with IP multicast devices.

IGMPv1, v2, v3, IGMP snooping querier mode, IGMP report suppression, topology change notification and robustness variable features are supported

Port Quick Disconnect	In some network environments, it is desirable to move an Ethernet from one switch port to another and have the device come on-line quickly. The Port Quick Disconnect feature if enabled, provides an immediate age-out of the MAC addresses learned on the port when the port status changes from a link-up to a link-down state
-----------------------	---

Manageability Features

Web Device Manager	The Perle Web Device Manager is an embedded Web based application that provides an easy to use browser interface for managing the switch. Unlike competitive products, Java applet technology is not required or used
Command Line Interface (CLI)	A familiar text-based Command Line Interface that is based on accepted industry standard syntax and structure. Ideal for CCNA and CCNP trained engineers, this interface is available via in-band Telnet or the out-band serial console port
SNMP	Manage the switch with an SNMP compatible management station that is running platforms such as HP Openview or Perle's PerleVIEW NMS. SNMP V1 and V2C
PerleVIEW	PerleVIEW is Perle's SNMP-based network management system that provides a view of the network with a large scale of Perle networking devices.
IPv6	Manage with an IPv4 or IPV6 address
DHCP Client Auto-Configuration	Automates configuration of switch information such as IP address, default gateway, hostname and Domain Name System (DNS) as well as TFTP server names. Firmware and configuration file locations are provided through options 54, 66, 67, 125 and 150
DHCP Relay	DHCP Relay is used for forwarding requests from DHCP clients when they are not on the same physical subnet. As a DHCP relay agent the switch operates as a Layer 3 device that forwards DHCP packets between clients and servers.
DHCP Option 82 Insertion	Normally used in metro or large enterprise deployments DHCP Option 82 insertion is used to provide additional information on "physical attachment" of the client. As per RFC 3046, option 82 enables additional pre-defined information to be inserted into the DHCP request packet (for DHCP Servers that support this option)
LLDP	LLDP-Link Layer Discovery Protocol as per IEEE 802.1AB is a neighbor discovery protocol that is used for network devices to advertise information about themselves to other devices on the network. This protocol runs over the data-link layer, which allows two systems running different network layer protocols to learn about each other (via TLVs – Type-Length-Value)

File Download	Firmware can be transferred via TFTP or HTTP. Text-based files that can be created or edited by common text editors.
---------------	--

Availability and Redundancy Features

Spanning Tree Protocol (STP)	IEEE 802.1D now incorporated in IEEE 802.1Q-2014, STP prevents bridge loops and the broadcast radiation that results from them.
--------------------------------	---

Other Spanning Tree features include BPDU guard, Root guard, loop guard, root guard and TCN Guard

Rapid Spanning Tree Protocol (RSTP)	Interoperable with STP, RSTP (IEEE 802.1w) takes advantage of point-to-point wiring and provides rapid convergence of the spanning tree. Reconfiguration of the spanning tree can occur in less than 1 second
---------------------------------------	---

P-Ring	Perle's Ring Protocol provides resilient operation of a network made up of managed switches in a ring topology. The implementation prevents a switch loop scenario and also enables communication within the ring if a failure occurs somewhere in the ring.
---------------	--

P-Ring also has an auto-configuration feature that automatically determines the master control switch in the ring reducing installation time.

Recovery time of 10 ms or better in rings composed of up to 14 switches

VLAN Features

VLAN Range	Up to 255 VLANS across a VLAN ID range of 1 to 4094
------------	---

VLAN Interfaces	Perle switches provide the ability to configure management VLAN interfaces. This enables network administrators to access the switch's management interface from separate VLAN networks
-----------------	---

Quality of Service (QoS) and Class of Service (CoS) Features

Classification	IP ToS/DSCP and IEEE 802.1p CoS
----------------	---------------------------------

Congestion Avoidance	Weighted Fair Queuing or Strict Queuing
----------------------	---

Egress Queues and scheduling	<ul style="list-style-type: none">• 4 traffic class queues per port• output queue mapping• DSCP to output queue mapping
------------------------------	---

Monitoring Features

Port Mirroring	N:1 Port Mirroring is a method of monitoring network traffic. With port mirroring enabled, the switch sends a copy of one or more ports to a predefined destination port. Selection of Transmit, Receive frames or both can be made
RMON	RMON statistics provided for statistics, history, alarms and events for network monitoring and traffic analysis
Syslog	Facility for logging systems messages to an external SYSLOG server
Alert Log	Facility for logging systems messages locally
Traceroute	Layer 2 traceroute to identify the path that a frame takes from source to destination
Virtual cable test	A test that enables the detection of potential copper cabling issues such as pair polarity pair swaps and excessive pair skew as well as any opens, shorts or any impedance mismatch. Will report the distance in the cable to the open or short.
SFP Diagnostics and Monitoring	Interface provided to the SFP's Digital Optical Monitoring facility to monitor operational or physical operating status of the SFP and link
Power Supply Monitoring	Provides the status of power supplies of the switch

Alarm
Processing

The switch can monitor global switch conditions as well as individual ports. These alarms can be configured to send messages to ;

- an internal log file
- external Syslog server
- SNMP trap server
- An external alarm device such as a bell, light or other signaling device via the switch's built-in dry contact alarm relay

Global Status Monitoring Alarms

- Dual power supply alarm

Port Status Monitoring Alarms

- Link Fault Alarm (IE loss of signal)
- Port not forwarding alarm
- Port not operating alarm (failure upon start up tests)
- FCS Bit error rate alarm

Alarm Relay

When enabled, energizes the built-alarm relay triggering an external alarm circuit such as a bell, light or other signaling device according to alarm conditions set

Management and Standards

IEEE
Standards

IEEE 802.3 for 10Base-T
IEEE 802.3u for 100BaseT(X) and 100BaseX
IEEE 802.3ab for 1000Base-T
IEEE 802.3z for 1000BaseX
IEEE 802.3x for Flow Control
IEEE 802.1D-2004 for Spanning Tree Protocol
IEEE 802.1w for Rapid STP
IEEE 802.1Q for VLAN Tagging
IEEE 802.1p for Class of Service
IEEE 802.3ad for Port Trunk with LACP
IEEE 802.1AB LLDP

SNMP MIB
Objects

RFC 1213-MIB II
RFC 1493-BRIDGE-MIB
RFC 1907-SNMPv2-MIB
RFC 2012-TCP-MIB
RFC 2013-UDP-MIB
RFC 2578-SNMPv2-SMI
RFC 2579-SNMPv2-TC
RFC 2819-RMON-MIB
RFC 4502-RMON2-MIB
RFC 2613-SMON-MIB
RFC 2863-IF-MIB
RFC 4363-Q-Bridge-MIB and P-Bridge MIB
RFC 4318-RSTP-MIB
IP-MIB
LLDP-MIB

Hardware Features & Technical Specifications: IDS-206 Industrial Managed DIN Rail Switch

Power

Dual Power Input Both inputs draw power simultaneously. If one power source fails, the other live source can, acting as a backup, supply enough power to meet the operational needs of the switch.

12/24/48 VDC Nominal. (9.6 to 60 VDC)

Power Connector 4-Pin Removable Terminal Block.

Grounding screw on metal chassis

Overload Current Protection Fused overload current protection

Reverse polarity protection The positive and negative inputs can be reversed providing safe and simple power connectivity.

Access Ports

RJ45	5 shielded RJ45 ports for 10/100/1000Base-T up to 100 meters (328 ft.)
	Auto-negotiation
	Auto-MDI/MDIX-crossover for use with either crossover over straight-through cable types
	Ethernet isolation 1500 V

RJ45 Serial Console port	RJ45 DTE Optional rolled and straight thru RJ45 cables and DB adapters are available
--------------------------	---

Small Form Factor Pluggable (SFP) slot	SFP slot for 100/1000Base-X SFP modules supplied by Perle , Cisco or other manufacturers of MSA compliant SFPs
--	--

Alarms

Alarm Relay	<ul style="list-style-type: none"> • NC (Normally Closed) dry contact. • 1A @ 24V
-------------	---

Switch Properties

Standards	IEEE 802.3 for 10Base-T
	IEEE 802.3u for 100Base-TX and 100Base-FX
	IEEE 802.3ab for 1000Base-T
	IEEE 802.3z for 1000BaseX
	Energy Efficient Ethernet (EEE) as per 802.3az.
	IEEE 802.3x for Flow Control

Processing Type	Store and Forward
-----------------	-------------------

MAC Address Table Size	8K
------------------------	----

VLAN ID range	1 to 4094
---------------	-----------

IGMP groups	1024
-------------	------

Packet Buffer Memory	1 Mbit
----------------------	--------

Jumbo Frame Size	10 KB
------------------	-------

Indicators

Power	This LED is turned on when the appropriate level of voltage is applied to one or both of the power inputs
-------	---

System	Indicates whether the switch O/S is operating normally
--------	--

RJ45 Ethernet	These integrated colored LEDs indicate link, activity and speed for each port.
---------------	--

Fiber Link	Fiber link LED indicates Link and Data Activity
------------	---

Alarm	The alarm LED (Red) will be turned on under alarm conditions
-------	--

P-Ring Master LED	Status of the P-Ring Master
-------------------	-----------------------------

Backup Network Coupling	Indicates whether or not the "Backup Network Coupling" feature is enabled (Redundant links connecting two P-Ring networks)
-------------------------	--

Environmental Specifications

Operating Temperature Ranges	Standard temperature models (Std) : -10° C to 60° C (14° F to 140° F).
	XT Industrial extended temperature models (Ind) : -40° C to 75° C (-40 F to 167° F)

Storage Temperature Range	Minimum range of -25° C to 75° C (-13° F to 167° F). -40 C to 85 C (-40 F to 185 F) for industrial extended temperature models
---------------------------	--

Operating Humidity Range	5% to 90% non-condensing
--------------------------	--------------------------

Storage Humidity Range	5% to 95% non-condensing
------------------------	--------------------------

Operating Altitude	Up to 3,048 meters (10,000 feet)
--------------------	----------------------------------

Chassis	Metal with an IP20 ingress protection rating
---------	--

Din Rail Mountable	DIN Rail attachment included. Mounts to standard 35 mm DIN rail in accordance with DIN EN 60175.
--------------------	--

Removable to accommodate optional Panel/Wall mount kit

Product Weight and Dimensions

Weight	0.61kg (1.34 lbs)
--------	---------------------

Dimensions	45 x 130 x 121mm
------------	------------------

Packaging

Shipping Weight	0.76kg (1.76 lbs)
-----------------	---------------------

Shipping Dimensions	170 x 260 x 70 mm
---------------------	-------------------

Standards and Certifications

Laser Safety	EN 60825-1:2007
--------------	-----------------

Fiber optic transmitters on this device meet Class 1 Laser safety requirements per IEC-60825 FDA/CDRH standards and comply with 21CFR1040.10 and 21CFR1040.11.

Safety	<p>UL 60950-1</p> <p>IEC 60950-1:2005+A1:2009 and</p> <p>EN 60950-1:2006+A11:2009+A1:2010+A12:2011</p> <p>CE Mark</p> <p>UL 61010-1 and UL 61010-2-201 (Standard for Safety for Programmable Controllers)</p>
Emissions	<p>FCC 47 Part 15 Class A</p> <p>CISPR 22:2008/EN55022:2010 (Class A)</p> <p>CISPR 24:2010/EN 55024:2010</p>
EMC and Immunity	<p>CISPR 24:2010/EN 55024:2010</p> <p>IEC/EN 61000-4-2 (ESD)</p> <p>IEC/EN 61000-4-3 (RS)</p> <p>IEC/EN 61000-4-4 (EFT)</p> <p>IEC/EN 61000-4-5 (Surge)</p> <p>IEC/EN 61000-4-6 (CS)</p> <p>IEC/EN 61000-4-8 (Magnetic Field)</p> <p>IEC/EN 61000-6-2 (General Immunity in Industrial Environments)</p>
Industrial Safety	<p>UL 61010-1 and UL 61010-2-201 (Standard for Safety for Programmable Controllers). Formerly known as UL508 (Safety standard for Industrial Control Equipment)</p>
Hazardous Locations (Hazloc)	<p>ANSI/ISA 12.12.01, Class 1 Division 2 Groups A-D (formerly known as UL 1604) *</p> <p>ATEX Class 1 Zone 2 *</p>
Environmental	<p>Reach, RoHS and WEEE Compliant</p>
Other	<p>ECCN: 5A991A</p> <p>HTSUS Number: 8517.62.0050</p> <p>5 year Warranty</p>

Contents Shipped

- Industrial Ethernet Switch with DIN Rail attachment
- Terminal block
- Installation guide

* pending

IDS-206 Industrial Switch Diagram

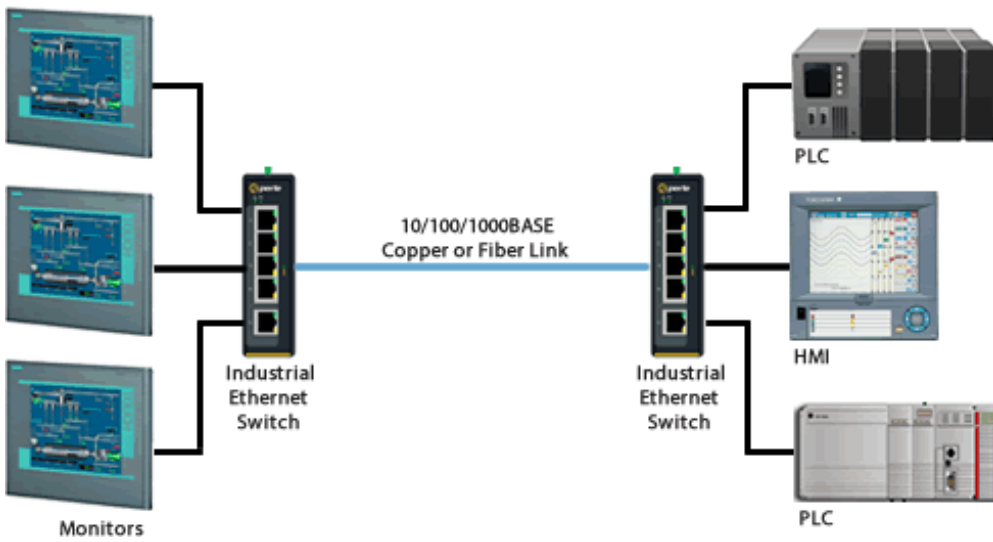

Select a Model to obtain a Part Number – IDS-206

Std = Standard Temperature models: -10° C to 60° C (14° F to 140° F).

Ind = Industrial Extended Temperature Models: -40° C to 75° C (-40 F to 167° F)

Duplex Fiber

Transmit (dBm) Receive (dBm)

Min Max Min Max

Model	Temp	RJ45 GE	Fiber Connector	Power Budget (dB)	Wavelength (nm)	Fiber Type	Operating Distance
-------	------	---------	-----------------	-------------------	-----------------	------------	--------------------

IDS-206	Std	5	1 SFP Slot (empty) 100Base-X 1000Base-X	Fiber specifications are dependent upon the choice of SFP used
IDS-206-XT	Ind	5	1 SFP Slot (empty) 100Base-X 1000Base-X	Fiber specifications are dependent upon the choice of SFP used

Industrial Ethernet Switch Accessories

Panel Mount kit PM3	Brackets for attaching 30 to 75 mm wide Perle IDS industrial switches inside a control panel or to a wall for wall.			
Rack Mount Kit RM4U	Bracket for mounting Perle DIN Rail switches in a standard 19" rack. Occupies "4U" of vertical rack space. 275 mm (10 inches) deep			
DIN Rail 24V Power Supply	IDPS-24-40-XT - DIN-Rail 24 VDC, 40Watt power supply with universal 85 to 264 VAC or 120-370 VDC input, -20 to 70°C extended operating temperature. Power Supply Specifications .			
DBA0020C	RJ-45F to DB-9F crossover (DTE) adapter for Perle serial console ports with Sun/Cisco pinout. #1100300-10			