

# IDS-509-SFP Managed Industrial Ethernet Switch

 [perle.com/products/switches/ids-509-sfp-industrial-managed-gigabit-switch.shtml](https://perle.com/products/switches/ids-509-sfp-industrial-managed-gigabit-switch.shtml)

## 9 port Compact DIN Rail Switch

- 10/100/1000Base-T ( RJ45 ) ports for Gigabit and Fast Ethernet devices
- 100/1000Base-X SFP fiber ports (empty)
- PRO feature set including advanced switching, encryption and [IEEE 1588 PTP](#)
- IP Manageability, VLAN and resiliency management
- Digital inputs for generation of alerts
- Compact, corrosion resistant case attaches to a standard DIN Rail
- Redundant dual power input 12/24/48 VDC, 24 VAC
- Out-of-band management via RJ45 or USB serial ports
- Programmable Controller safety and Hazardous Location Certification
- -40 to 75C industrial operating temperature ( XT Models )

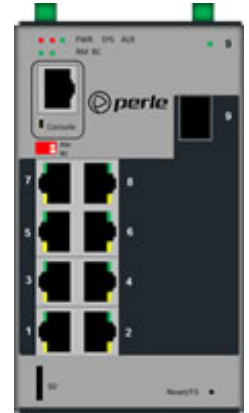

The **IDS-509-SFP** is a **9 port Managed Ethernet Switch** that can operate in **industrial environments** providing advanced performance and enabling **real-time deterministic network operation**. Choose any combination of **10/100/1000-Base-T Ethernet copper ports** and **100/1000Base-X SFP fiber ports** to meet the needs of your environment.

- 8 copper, 1 SFP fiber
- 7 copper, 2 SFP fiber
- 6 copper, 3 SFP fiber
- 4 copper, 5 SFP fiber

The SFP slots allow for flexible network configurations using [SFP transceivers supplied by Perle, Cisco](#) or other manufacturers of MSA compliant SFPs. In addition, they make **utilizing fiber is easy** in environments where **high levels of electromagnetic interference ( EMI )** is a common phenomenon, like industrial plants. This interference can cause data corruption over copper-based Ethernet links. However, data transmitted over fiber optic cable is completely immune to this type of noise ensuring optimal data transmission across the plant floor.

Perle **Industrial-grade Ethernet Switches** are designed to stand up to **extreme temperatures, surges, vibrations, and shocks** found in **industrial automation, government, military, oil and gas, mining and outdoor applications**.

Simple **Plug and Play** installation to get your Ethernet devices networked immediately is available with Perle's **Fast Setup feature**. **CCNA** ( Cisco Certified Network Associate ) and **CCNP** ( Cisco Certified Network Professional ) trained engineers will appreciate the familiar **Command Line Interface ( CLI )** via in-band Telnet or the out-band serial console port.

The **PRO feature set** in the IDS-509-SFP is ideal for advanced environments where additional extensive **security** and **network integration** functionality is required.

- [AAA \( Authentication, Authorization, Accounting \)](#) security protocols: RADIUS and TACACS+

- SSH, SNMPv3, Telnet and HTTPS [secure management sessions](#)
- [Management Access Lists](#) (ACL) by IP address and IP Port number
- Enforce [Password Strength](#) requirements
- [IEEE 802.1x Authentication and Port Security](#) for protection of user access ports
- Optimize the performance and intelligence of the network with [Advanced Protocols](#): LLDP, GVRP, Voice VLANs, MSTP, GMRP, IPv4 IGMP Snooping and IPv6 MLD Snooping

The **IDS-509-SFP** supports a comprehensive set of management functions, such as [P-Ring](#), **management VLAN**, **QoS**, **RMON**, **N:1 port mirroring** and **local alert log**. In addition, the switch can be **managed with an IPv6 address**.

All IDS-509-SFP models, are **rugged fan-less switches** that are hardened to provide superior reliability in **-10 to 60°C**. In addition, **every component** on every **industrial (XT) model** has been **designed and tested** to handle operating temperatures between **-40 and 75C**..

All Perle Industrial Ethernet Switches only use **high-end components** from the **leading chip manufacturers** to ensure the highest level of **durability and reliability**. In addition, all units have a corrosion resistance aluminum case and dual redundant power input with reverse polarity and overload protection.

For **over 35 years** Perle has been **designing industrial hardware**. This expertise was used to design the **toughest Ethernet switches on the market** that will keep your system running for years to come.

## IDS-509-SFP Industrial Managed DIN Rail Switch Features

Simple deployment	Zero-touch discovery using Dynamic Host Control Protocol (DHCP), Perle’s “Fast Setup” for first time installation, provides simple deployment in Ethernet environments
Security	<a href="#">802.1X</a> , <a href="#">port security</a> , <a href="#">Secure Shell (SSHv2)</a> ; <a href="#">SNMPv3</a> provides encrypted administrator traffic during CLI and SNMP sessions; <a href="#">TACACS+</a> and <a href="#">RADIUS</a> authentication facilitate centralized control and restrict unauthorized users.
Resiliency	<ul style="list-style-type: none"> <li>• STP, RSTP and MSTP protocols for fast recovery.</li> <li>• Perle’s <a href="#">P-Ring protocol</a> for fast convergence in ring topologies</li> <li>• Link Standby is a link recovery feature for two links that provides a simple alternative to spanning tree protocols for link redundancy</li> <li>• Buffered Real Time Clock backup</li> </ul>
Manageability	<ul style="list-style-type: none"> <li>• Web Device Manager, Telnet/SSH, HTTPS access, SNMP and Perle’s <a href="#">PerleView</a> NMS for centralized management</li> <li>• Use an IPv4 or IPv6 address</li> <li>• In-band management via RJ45 or USB serial port</li> <li>• Removable MicroSD flash for configuration files and firmware backup and restoration</li> </ul>

---

Rugged design for harsh environments

- Corrosion resistant case
- Programmable Controller Safety certified
- Certified for hazardous locations
- Extended industrial temperature models

---

Reliable operation

- Fan-less, no moving parts
- Dual power input. Connect to separate power sources for redundancy.
  - Reverse polarity protection
  - Overload current protection
- Handles vibration and shock conditions found in industrial environments

---

Real-time Ethernet performance

- Fast wire-speed , store and forward switching
- Auto-sensing for speed and duplex
- Auto-mdi/mdix-crossover works with straight and crossover cables

---

### Performance Features

---

Port Auto-sensing

Auto-sensing of port speed and auto-negotiation of duplex on all switch ports for optimizing bandwidth

---

Auto MDI/MDIX

Medium-dependent interface crossover ( Auto-MDIX ) capability on 10/100 and 10/100/1000 mbps interfaces that enables the interface to automatically detect the required cable type ( straight thru or crossover ) and to configure the connection appropriately

---

802.3x flow control

IEEE 802.3x flow control on all ports. ( The switch does not initiate pause frames )

---

Link Aggregation protocol

Increase port bandwidth through link aggregation. Support is provided for IEEE 802.3ad using Link Aggregation Control Protocol ( LACP ). Up to eight ( 8 ) ports in a single port-channel

---

Static Link Aggregation

Provides the ability to operate under a static ( manual ) link aggregation scenario ( where the remote switch peer does not support LACP )

---

Storm Control

Storm control prevents traffic on a LAN from being disrupted by a broadcast, multicast, or unicast storm on one of the physical interfaces. A LAN storm occurs when packets flood the LAN, creating excessive traffic and degrading network performance. Storm Control enables limits to be placed on broadcast, multicast and unicast traffic

---

Bandwidth Control Monitoring

Bandwidth Control provides the ability to monitor the flow rates on a per port basis and the ability to cause an SNMP trap to occur ( selectable ) and put the port in an "error-disabled" state

---

Static MAC Addressing	This feature enables the manual configuration of the MAC addresses on a per port basis. Flooding is prevented by retaining MAC entries across a reboot of the switch.
Port Blocking	Port Blocking provides the ability to block the flooding of unknown layer 2 unicast and multicast traffic on an Interface
IPV4 IGMP Snooping	Internet Group Management Protocol ( IGMP ) constrains the flooding of multicast traffic by dynamically configuring Layer 2 interfaces so that multicast traffic is forwarded to only those interfaces associated with IP multicast devices.  IGMPv1, v2, v3, IGMP snooping querier mode, IGMP report suppression, topology change notification and robustness variable features are supported
IPV6 MLD Snooping	With Multicast Listener Discovery ( MLD) snooping, IPv6 multicast data is selectively forwarded to a list of ports that want to receive the data, instead of being flooded to all ports in a VLAN. This list is constructed by snooping IPv6 multicast control packets
GMRP	GARP Multicast Registration Protocol ( GMRP ) provides a constrained multicast flooding facility similar to IGMP snooping.  GMRP provides a mechanism that allows bridges and end stations to dynamically register group membership information with the MAC bridges attached to the same LAN segment and for that information to be disseminated across all bridges in the Bridged LAN that supports extended filtering services
Port Quick Disconnect	In some network environments, it is desirable to move an Ethernet from one switch port to another and have the device come on-line quickly. The Port Quick Disconnect feature if enabled, provides an immediate age-out of the MAC addresses learned on the port when the port status changes from a link-up to a link-down state
<b>Manageability Features</b>	
Web Device Manager	The Perle Web Device Manager is an embedded Web based application that provides an easy to use browser interface for managing the switch. Operates with both http and secure https streams. Unlike competitive products, Java applet technology is not required or used
Command Line Interface ( CLI )	A familiar text-based Command Line Interface that is based on accepted industry standard syntax and structure. Ideal for CCNA and CCNP trained engineers, this interface is available via in-band Telnet/SSH or the out-band serial console port
SNMP	Manage the switch with an SNMP compatible management station that is running platforms such as HP Openview or Perle's PerleVIEW NMS. SNMP V1, V2C, V3
<b>PerleVIEW</b>	PerleVIEW is Perle's SNMP-based network management system that provides a view of the network with a large scale of Perle networking devices.
IPv6	Manage with an IPv4 or IPV6 address
DHCP Client Auto-Configuration	Automates configuration of switch information such as IP address, default gateway, hostname and Domain Name System ( DNS ) as well as TFTP server names. Firmware and configuration file locations are provided through options 54, 66, 67, 125 and 150

DHCP Relay	DHCP Relay is used for forwarding requests from DHCP clients when they are not on the same physical subnet. As a DHCP relay agent the switch operates as a Layer 3 device that forwards DHCP packets between clients and servers.
DHCP Option 82 Insertion	Normally used in metro or large enterprise deployments DHCP Option 82 insertion is used to provide additional information on “physical attachment” of the client. As per RFC 3046, option 82 enables additional pre-defined information to be inserted into the DHCP request packet ( for DHCP Servers that support this option )
DHCP Server	For networks where a central DHCP server is not provided, the switch can provide a DHCP Server function for allocation of IP addresses to the connected devices
DHCP server port-based address allocation	<p>When Ethernet switches are deployed in the network, they offer connectivity to the directly connected devices. In some environments, such as on a factory floor, if a device fails, the replacement device must be working immediately in the existing network</p> <p>When configured, the DHCP server port-based address allocation feature ensures that the same IP address is always offered to the same connected port even as the client identifier or client hardware address changes in the DHCP messages received on that port</p>
LLDP	LLDP-Link Layer Discovery Protocol as per IEEE 802.1AB is a neighbor discovery protocol that is used for network devices to advertise information about themselves to other devices on the network. This protocol runs over the data-link layer, which allows two systems running different network layer protocols to learn about each other ( via TLVs – Type-Length-Value )
LLDP-MED	LLDP Media Endpoint Discovery is an extension to LLDP that operates between endpoint devices such as IP phones and network devices such as switches. It specifically provides support for voice over IP (VoIP) applications and provides additional TLVs for capabilities discovery, network policy, Power over Ethernet, inventory management and location information
NTP	The switch can provide the time to NTP/SNTP capable client devices ( or other switches, etc ). You can run the SNTP client and the NTP server concurrently on your system. Therefore you can obtain time from an outside source and serve that time to the devices connected to the switch.
<b>IEEE 1588 – PTP ( Precision Time Protocol )</b>	<ul style="list-style-type: none"> <li>• IEEE 1588 V1 and V2</li> <li>• Boundary Clock V1</li> <li>• Boundary Clock V2</li> <li>• End-to-End Transparent Clock Sync Two Step Operation</li> <li>• End-to-End Transparent Clock Sync One Step Operation</li> <li>• Peer-to-Peer Transparent Clock</li> <li>• End-to-end Boundary clock</li> <li>• Peer-to-peer boundary clock</li> <li>• Microsecond accuracy</li> </ul>
File Download	Firmware can be transferred via TFTP, SCP, HTTP, HTTPS or via insertion of a microSD card. Text-based files that can be created or edited by common text editors.

---

Secure Copy Protocol ( SCP )	SCP based on the Secure Shell (SSH) protocol, is a means of securely transferring computer files between a local host and a remote host or between two remote hosts.
------------------------------	--

---

### Availability and Redundancy Features

---

Spanning Tree Protocol ( STP )	IEEE 802.1D now incorporated in IEEE 802.1Q-2014, STP prevents bridge loops and the broadcast radiation that results from them.  Other Spanning Tree features include BPDU guard, Root guard, loop guard, root guard and TCN Guard
--------------------------------	--

---

Rapid Spanning Tree Protocol ( RSTP )	Interoperable with STP, RSTP ( IEEE 802.1w ) takes advantage of point-to-point wiring and provides rapid convergence of the spanning tree. Reconfiguration of the spanning tree can occur in less than 1 second
---------------------------------------	---

---

Multiple Spanning Tree Protocol ( MSTP )	Originally defined in IEEE 802.1s and now incorporated IEEE 802.1Q-2014, defines an extension to RSTP for use with VLANs. The Multiple Spanning Tree Protocol configures a separate Spanning Tree for each VLAN group and blocks all but one of the possible alternate paths within each Spanning Tree.
--	---

---

P-Ring	Perle's Ring Protocol provides resilient operation of a network made up of managed switches in a ring topology. The implementation prevents a switch loop scenario and also enables communication within the ring if a failure occurs somewhere in the ring.
--------	--

---

Link Standby	A link recovery feature using a primary and backup link. Provides a simple alternative to spanning tree protocols for link redundancy
--------------	---

---

### VLAN Features

---

VLAN Range	Up to 256 VLANS across a VLAN ID range of 1 to 4000
------------	---

---

GVRP	Generic Attribute Registration Protocol (GARP) VLAN Registration Protocol (GVRP) is an application defined in the IEEE 802.1Q standard that allows for the control of VLANs. With GVRP, the switch can exchange VLAN configuration information with other GVRP switches, prune unnecessary broadcast and unknown unicast traffic, and dynamically create and manage VLANs on switches that are connected through 802.1Q trunk ports.
------	--

---

Voice VLANs	Voice VLANs enables one to separate, prioritize, and authenticate voice traffic moving through your network, and to avoid the possibility of broadcast storms affecting VoIP (Voice-over-IP) operation. With an IP Phone connected to an access port, a switchport voice VLAN enables the use of one VLAN for voice traffic and another VLAN for data traffic from an Ethernet device attached to the phone
-------------	---

---

VLAN Interfaces	Perle switches provide the ability to configure management VLAN interfaces. This enables network administrators to access the switch's management interface from separate VLAN networks
-----------------	---

---

### Security Features

---

---

## IEEE 802.1X

- Provides secure access to switch ports from a central RADIUS server. The switch operating as an authenticator interacting with an 802.1X compliant supplicant ( PC or industrial device) through the use of the EAPOL protocol. Authentication will be granted/denied through an external RADIUS server.
- RADIUS assigned VLAN
  - IETF 64 (Tunnel Type)
  - IETF 65 (Tunnel Medium Type)
  - IETF 81 (Tunnel Private Group ID)
- Guest VLAN and Restricted VLANs are supported
- For non-802.1X devices found in industrial applications, the switch can use the client MAC address for authorization through the use of MAB ( MAC Authentication Bypass )
- Switch can also be configured as an 802.1X supplicant ( edge switch ) with an 802.1x-aware upstream switch

---

### Login Banner and MOTD

A login message banner presented during sign-on can be configured by the network administrator.

A Message Of The Day can also be created for presentation to an authenticated user.

---

### Password Strength Checking

Many organizations require stringent management over the strength level of their passwords. When enabled, Perle extends this capability to local passwords stored on the switch enforcing strong passwords to be used.

---

### Port Security – Secure MAC Addresses

This port security feature provides the ability to restrict input to an interface by limiting and identifying MAC addresses of the stations allowed to access the port ( Access or Trunk ) and will take specific actions when violations occur.

---

### Management ACL

Restricting access to management functions can be configured by protocol or IP address selection are provided. This enables administrators to allow only specific workstations using particular protocols to be able to access the management functions of the switch

---

### RADIUS Management Access Authentication

[AAA support](#) for RADIUS servers that Authenticate, Authorize and Account management sessions

---

### TACACS+ Management Access Authentication

AAA support for TACACS+ servers that Authenticate, Authorize and Account management sessions

---

### Secure Socket Layer ( SSL )

SSL provided for [secure browser sessions](#) using HTTPS

---

### Secure Shell ( SSH )

SSH provided for secure SSH session for CLI and SCP file transfer sessions

---

SNMPV3	Support provided for secure version 3 of SNMP
<b>Quality of Service ( QoS ) and Class of Service ( CoS ) Features</b>	
Classification	IP ToS/DSCP and IEEE 802.1p CoS
Congestion Avoidance	Weighted Fair Queuing or Strict Queuing
Egress Queues and scheduling	<ul style="list-style-type: none"> <li>• 4 traffic class queues per port</li> <li>• output queue mapping</li> <li>• DSCP to output queue mapping</li> </ul>
<b>Monitoring Features</b>	
Port Mirroring	N:1 Port Mirroring is a method of monitoring network traffic. With port mirroring enabled, the switch sends a copy of one or more ports to a predefined destination port. Selection of Transmit, Receive frames or both can be made
RMON	RMON statistics provided for statistics, history, alarms and events for network monitoring and traffic analysis
Syslog	Facility for logging systems messages to an external SYSLOG server
Alert Log	Facility for logging systems messages locally
Traceroute	Layer 2 traceroute to identify the path that a frame takes from source to destination
Virtual cable test	A test that enables the detection of potential copper cabling issues such as pair polarity pair swaps and excessive pair skew as well as any opens, shorts or any impedance mismatch. Will report the distance in the cable to the open or short.
SFP Diagnostics and Monitoring	Interface provided to the SFP's Digital Optical Monitoring facility to monitor operational or physical operating status of the SFP and link
Power Supply Monitoring	Provides the status of power supplies of the switch
Internal Temperature Monitoring	The internal ambient temperature of the switch can be obtained from the management interfaces



---

Alarm Processing	The switch can monitor global switch conditions as well as individual ports. These alarms can be configured to send messages to ; <ul style="list-style-type: none"><li>• an internal log file</li><li>• external Syslog server</li><li>• SNMP trap server</li><li>• An external alarm device such as a bell, light or other signaling device via the switch's built-in dry contact alarm relay</li></ul>
------------------	---

Global Status Monitoring Alarms

- Dual power supply alarm

Port Status Monitoring Alarms

- Link Fault Alarm ( IE loss of signal )
- Port not forwarding alarm
- Port not operating alarm ( failure upon start up tests )
- FCS Bit error rate alarm

---

Alarm Relay	When enabled, energizes the built-alarm relay triggering an external alarm circuit such as a bell, light or other signaling device according to alarm conditions set
-------------	--

---

### Management and Standards

---

IEEE Standards	IEEE 802.3 for 10Base-T IEEE 802.3u for 100BaseT(X) and 100BaseX IEEE 802.3ab for 1000Base-T IEEE 802.3z for 1000BaseX IEEE 802.3x for Flow Control IEEE 802.1D-2004 for Spanning Tree Protocol IEEE 802.1w for Rapid STP IEEE 802.1s for Multiple Spanning Tree Protocol IEEE 802.1Q for VLAN Tagging IEEE 802.1p for Class of Service IEEE 802.1X for Authentication IEEE 802.3ad for Port Trunk with LACP IEEE 802.1AB LLDP IEEE 1588v1 PTP Precision Time Protocol IEEE 1588v2 PTP Precision Time Protocol
----------------	--

---

SNMP MIB Objects	IEEE8021-PAE-MIB NTPv4-MIB IEEE8021-SPANNING-TREE-MIB SYSAPPL-MIB LLDP-EXT-MED-MIB SNMP-COMMUNITY-MIB LLDP-EXT-MED-MIB IGMP-STD-MIB IEEE8021-MSTP-MIB Q-BRIDGE-MIB LLDP-EXT-DOT3-MIB IF-MIB RSTP-MIB DIFFSERV-DSCP-TC
------------------	--

LLDP-EXT-DOT1-MIB  
IEEE8021-TC-MIB  
LLDP-MIB  
RMON2-MIB  
ENTITY-MIB  
P-BRIDGE-MIB  
PERLE-LOGIN-MIB  
PERLE-ALERT-MIB  
PERLE-IP-SSH-MIB  
PERLE-IP-PROTOCOLS-MIB  
PERLE-USER-MIB  
PERLE-SMI  
PERLE-MAC-NOTIFICATION-MIB  
PERLE-SYSINFO-MIB  
PERLE-LINKSTANDBY-MIB  
PERLE-AAA-MIB  
perle-AAA.MIB  
PERLE-IPV6-MIB  
PERLE-LOGGING-MIB  
PERLE-VLAN-MIB  
PERLE-IF-MIB  
PERLE-ENTITY-VENDORTYPE-OID-MIB  
PERLE-ERR-DISABLE-MIB  
PERLE-SWITCH-PLATFORM-MIB  
PERLE-ENVMON-MIB  
PERLE-TIME-MIB  
PERLE-PTP-MIB  
PERLE-P-RING-MIB  
PERLE-SNMP-MIB  
PERLE-FILE-TRANSFER-MIB  
PERLE-SWITCH-GLOBAL-MIB  
PERLE-BOOT-MIB  
PERLE-PRODUCTS-MIB  
PERLE-BANDWIDTH-CONTROL-MIB  
PERLE-IP-TELNET-MIB  
PERLE-GVRP-MIB  
PERLE-PORT-SECURITY-MIB  
PERLE-DHCP-SERVER-MIB  
PERLE-GARP-MIB  
PERLE-ARCHIVE-MIB  
PERLE-NTP-MIB  
PERLE-SSL-MIB  
PERLE-IGMP-MIB  
PERLE-ACL-MIB  
PERLE-POE-MIB  
PERLE-RELOAD-MIB  
PERLE-ENTITY-ALARM-MIB  
PERLE-IPV6-NEIGHBOR-MIB  
PERLE-DOT1X-AUTH-MIB  
PERLE-TC  
PERLE-DHCP-CLIENT-MIB  
PERLE-LINE-MIB  
PERLE-ARP-MIB  
PERLE-GMRP-MIB  
PERLE-MLD-MIB  
PERLE-IP-HTTP-MIB  
PERLE-PORT-MONITOR-MIB  
PERLE-SpTreeExtensions-MIB  
PERLE-IP-MIB

---

## Hardware Features & Technical Specifications: IDS-509-SFP Industrial Managed DIN Rail Switch

### Power

---

Dual Power Input	Both inputs draw power simultaneously. If one power source fails, the other live source can, acting as a backup, supply enough power to meet the operational needs of the switch.  12/24/48 VDC Nominal. ( 9.6 to 60 VDC)  24 VAC Nominal ( 18 to 30 VAC )
Power Connector	4-Pin Removable Terminal Block.  Grounding screw on metal chassis
Maximum Current Consumption @24 vDC	1 SFP = 0.66 amps 2 SFP = 0.58 amps 3 SFP = 0.61 amps 5 SFP = 0.61 amps
Maximum Power Consumption @24 vDC	1 SFP = 15.8 watts 2 SFP = 14 watts 3 SFP = 14.7 watts 5 SFP = 14.7 watts
Overload Current Protection	Fused overload current protection
Reverse polarity protection	The positive and negative inputs can be reversed providing safe and simple power connectivity.

---

### Access Ports

---

RJ45	4, 6, 7 or 8 shielded RJ45 ports for 10/100/1000Base-T up to 100 meters ( 328 ft )  Auto-negotiation  Auto-MDI/MDIX-crossover for use with either crossover over straight-through cable types  Ethernet isolation 1500 V
RJ45 Serial Console port	RJ45 DTE Optional rolled and straight thru RJ45 cables and DB adapters are available
Small Form Factor Pluggable ( SFP ) slot	1,2 or 3 SFP slots for SERDES 100/1000Base-X <a href="#">SFP modules supplied by Perle, Cisco</a> or other manufacturers of MSA compliant SFPs  SFPs supporting the SGMII protocol are also supported ( example 1000Base-T )
USB Serial Console port	MicroUSB Type B female port for serial console management. Used as an alternative port for out of band management connections

---

Digital Inputs	Two Digital Inputs are provided that can be used for generation of alarms ( SNMP trap, energizing of on-board Alarm Relay,etc )
----------------	---

### Alarms

- NC (Normally Closed ) or NO ( Normally Open ) dry contact.
- 1A @ 24V

### Switch Properties

Standards	IEEE 802.3 for 10Base-T IEEE 802.3u for 100Base-TX and 100Base-FX IEEE 802.3ab for 1000Base-T IEEE 802.3z for 1000BaseX IEEE 802.3x for Flow Control
-----------	--

Processing Type	Store and Forward
-----------------	-------------------

MAC Address Table Size	8K
------------------------	----

VLAN ID range	1 to 4000
---------------	-----------

IGMP groups	1024
-------------	------

Packet Buffer Memory	1 Mbit
----------------------	--------

Jumbo Frame Size	10 KB
------------------	-------

### Indicators

Power	This LED is turned on when the appropriate level of voltage is applied to one or both of the power inputs
-------	---

System	Indicates whether the switch O/S is operating normally
--------	--

RJ45 Ethernet	These integrated colored LEDs indicate link, activity and speed for each port.
---------------	--

Fiber Link	Fiber link LED indicates Link and Data Activity
------------	---

Alarm	The alarm LED ( Red ) will be turned on under alarm conditions
-------	--

P-Ring Master LED	Status of the P-Ring Master
-------------------	-----------------------------

Backup Network Coupling	Indicates whether or not the "Backup Network Coupling" feature is enabled ( Redundant links connecting two P-Ring networks )
-------------------------	--

---

### External Configuration DIP Switches

---

S2	When enabled, designates this switch as the Ring Master
S1	Activate Backup Coupling between 2 ring networks

---

### Environmental Specifications

---

MTBF	<i>Calculation model based on MIL-HDBK-217-FN2 @ 30 °C</i>
Operating Temperature Ranges	Standard temperature models ( Std ): -10° C to 60° C (14° F to 140° F). XT Industrial extended temperature models ( Ind ): -40° C to 75° C ( -40 F to 167° F )
Storage Temperature Range	Minimum range of -25° C to 70° C (-13° F to 158° F). -40 C to 85 C (-40 F to 185 F) for industrial extended temperature models
Operating Humidity Range	5% to 90% non-condensing
Storage Humidity Range	5% to 95% non-condensing
Maximum Heat Output	1 SFP = 53.9 Btu/hr 2 SFP = 47.8 Btu/hr 3 SFP = 50.2 Btu/hr 5 SFP = 50.2 Btu/hr
Operating Altitude	Up to 3,048 meters (10,000 feet)
Chassis	Metal with an IP20 ingress protection rating
Din Rail Mountable	DIN Rail attachment included. Mounts to standard 35 mm DIN rail in accordance with DIN EN 60175.  Removable to accommodate optional Panel/Wall mount kit

---

### Product Weight and Dimensions

---

Weight	1.5 kg
Dimensions	75 x 130 x 121mm

---

### Packaging

---

Shipping Weight	2.0 kg
Shipping Dimensions	170 x 260 x 70 mm

---

### Standards and Certifications

---

Safety	<p>UL 60950-1</p> <p>IEC 60950-1:2005+A1:2009 and</p> <p>EN 60950-1:2006+A11:2009+A1:2010+A12:2011</p> <p>CE Mark</p> <p>UL 61010-1 and UL 61010-2-201 ( Standard for Safety for Programmable Controllers )</p>
Emissions	<p>FCC 47 Part 15 Class A</p> <p>CISPR 22:2008/EN55022:2010 (Class A)</p> <p>CISPR 24:2010/EN 55024:2010</p>
EMC and Immunity	<ul style="list-style-type: none"> <li>• CISPR 24:2010/EN 55024:2010</li> <li>• IEC/EN 61000-4-2 (ESD) : Contact discharge +/- 4kv, Air discharge +/- 8kv</li> <li>• IEC/EN 61000-4-3 (RS) : 80mhz to 1Ghz ; 10v/m, 1.4Ghz to 2.0ghz ; 5 v/m, 2.0ghz to 2.7 ghz ; 5 v/m</li> <li>• IEC/EN 61000-4-4 (EFT) : DC power line +/- 2kv, data line +/- 1kv</li> <li>• IEC/EN 61000-4-5 (Surge) : DC power line, Line/Line +/- 1kv, Line/Earth +/- 2kv, data line /earth +/- 2kv</li> <li>• IEC/EN 61000-4-6 (CS) :150khz-80Mhz 10vrms</li> <li>• IEC/EN 61000-4-8 (Magnetic Field) :30 A/M</li> <li>• IEC/EN 61000-6-2 ( General Immunity in Industrial Environments )</li> </ul>
Industrial Safety	<p>UL 61010-1 and UL 61010-2-201 ( Standard for Safety for Programmable Controllers ). Formerly known as UL508 (Safety standard for Industrial Control Equipment )</p>
Hazardous Locations ( Hazloc )	<p>ANSI/ISA 12.12.01, Class 1 Division 2 Groups A-D ( formerly known as UL 1604 ) *</p> <p>ATEX Class 1 Zone 2 *</p>
Environmental	<p><a href="#">Reach, RoHS and WEEE Compliant</a></p>
Other	<p>ECCN: 5A992</p> <p>HTSUS Number: 8517.62.0050</p> <p>5 year Warranty</p>
Contents Shipped	<ul style="list-style-type: none"> <li>• Industrial Ethernet Switch with DIN Rail attachment</li> <li>• Terminal block</li> <li>• Installation guide</li> </ul>

\* pending

## IDS-509-SFP Industrial Managed DIN Rail Switch

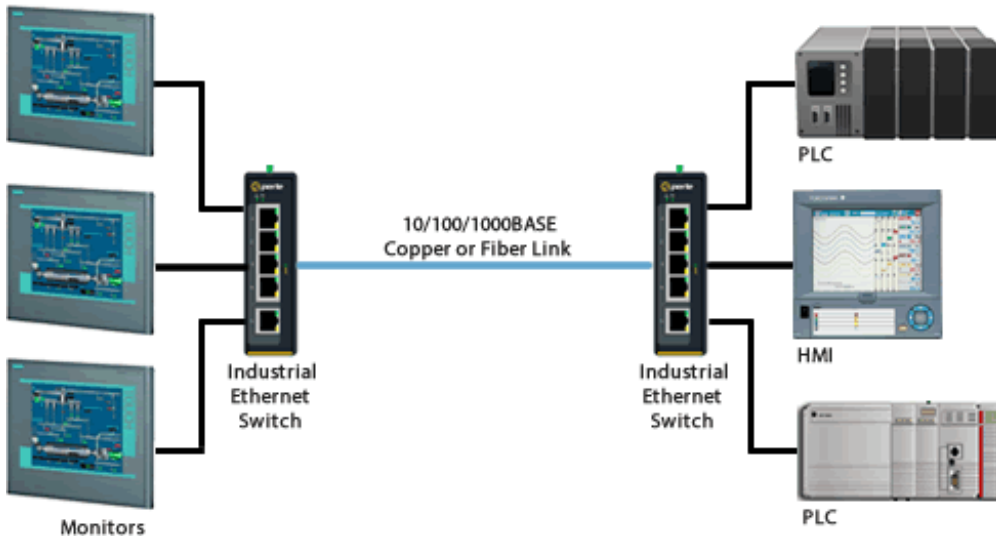

### Select a Model to obtain a Part Number – IDS-509-SFP

Std = Standard Temperature models: -10° C to 60° C (14° F to 140° F).

Ind = Industrial Extended Temperature Models: -40° C to 75° C ( -40 F to 167° F )

Model	Temp	SFP Slots (empty)	
		RJ45 ports 10/100/1000Base-T	100Base-X 1000Base-X
IDS-509-1SFP	Std	8	1
IDS-509-1SFP-XT	Ind	8	1
IDS-509-2SFP	Std	7	2
IDS-509-2SFP-XT	Ind	7	2
IDS-509-3SFP	Std	6	3
IDS-509-3SFP-XT	Ind	6	3
IDS-509-5SFP	Std	4	5
IDS-509-5SFP-XT	Ind	4	5

### Industrial Ethernet Switch Accessories

---

<a href="#">Panel Mount kit PM3</a>	Brackets for attaching 30 to 75 mm wide Perle IDS industrial switches inside a control panel or to a wall for wall.
<a href="#">Rack Mount Kit RM4U</a>	Bracket for mounting Perle DIN Rail switches in a standard 19" rack. Occupies "4U" of vertical rack space. 275 mm ( 10 inches ) deep
<a href="#">DIN Rail 24V Power Supply</a>	IDPS-24-40-XT - DIN-Rail 24 VDC, 40Watt power supply with universal 85 to 264 VAC or 120-370 VDC input, -20 to 70°C extended operating temperature. <a href="#">Power Supply Specifications</a> .
<a href="#">DBA0020C</a>	RJ-45F to DB-9F crossover (DTE) adapter for Perle serial console ports with Sun/Cisco pinout. #1100300-10

---