

Anytime, anywhere sense your vehicle.

InVehicle T320 Series Vehicle Telematics



The Vehicle Telematics 320 (also VT320) is capable of reliable operation in harsh environments even when the vehicle is powered off. Integrating LTE, GNSS, gyroscope and inertia sensor, equipped with powerful computing capabilities and a multitask system. VT320 precisely locates vehicle positions in real time, records mileage, monitors hard braking, acceleration, collision and other accidents, maintains transport safety, records and analyzes driving behavior.

Multiple I/O interfaces remotely monitor various vehicle peripherals such as alarms, sensors, switches, ignition status, controllers, etc. With standard vehicle protocols such as OBD-II, J1939 and J1708 supported, the VT320 tracks vehicle operation starts and delivers preventive maintenance. Featuring IP66 protection rating and low power consumption. Major fleet managers can rely on the VT320 to track and manage fleet vehicles and drivers with accuracy and efficiency.

Market Applications

+ Freight and Logistics

+ Heavy Equipment

+ Public Transportation

+ Generator Monitoring



InHand Networks

www.inhandnetworks.com

Features and Advantages

+ High Performance Asset Tracking Gateway

Available with LTE CAT M1, CAT 1 the VT320 continuously delivers reliable connectivity while being power-saving. Built-in GNSS module and inertial navigation for high-precision real-time location tracking; with the gyroscope, the VT320 enables continuous driving behavior monitoring and keeps you safe on the road.

+ Extensive Interfaces, Better Integration with Vehicles

Built with dual CAN Bus, the VT320 is perfect for vehicles like heavy equipment. It supports common vehicle diagnostic protocols such as OBD-II J1939 and J1708.

Extensive interfaces, including serial ports, I/O, Bluetooth, 1-Wire.

+ Multiple IoT Cloud Services Supported

AWS、Azure、Wialon、ThingsBoard、MQTT Cloud、Customer Private Cloud、Other

+ Continuous and Reliable Operation

Cache which over 30K location records, freeing you from concerns about data loss when Internet connection is unavailable.

+ Purpose Designed for Vehicles

IP66 protection rating, which protects the product from water and dust. Wide voltage range of 9-48V covers all types of vehicle power supplies. Powered by Ni-MH 1200mAh battery, the VT320 is able to continue working when the machine is turned off. Operating temperature range is $-40\text{ }^{\circ}\text{C} \sim 85\text{ }^{\circ}\text{C}$.

+ Easy for Installation

With built-in cellular and GNSS antennas, the VT320 is easy for installation and deployment on the road.

Dimensions and Interfaces

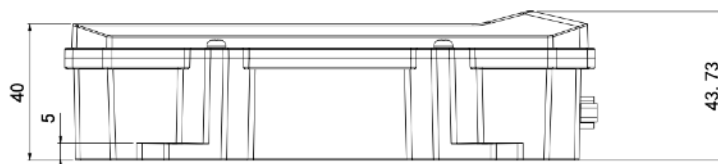
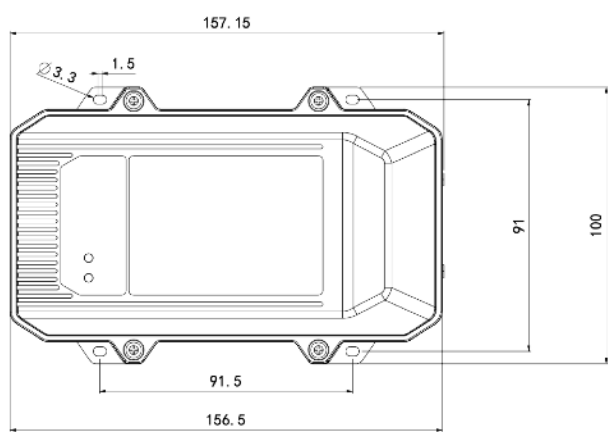

Product Specifications

InVehicle T320				
Network Type	LTE CAT 1 / CAT M			
Antenna	LTE FPC built-in antenna	GNSS Bluetooth Antenna	Ceramic built-in antenna	
GNSS (Global Navigation Satellite System)	Satellite Support	GPS Galileo Beidou GLONASS		
	Channel	72 channels		
	Sensitivity	-167 dBm, initial positioning time 26s		
	Tracking Sensitivity	-157 dBm (Hot start); -148 dBm (Cold start)		
	Location Accuracy	2.5m (CEP50)		
Inertial Sensor	Update Frequency	0.25 Hz ~ 10 MHz Configurable		
	Acceleration	Measurement range: $\pm 2 / \pm 4 / \pm 8 / \pm 16g$		
Inertial Sensor	Angular Velocity	Measurement range: $\pm 125 / \pm 250 / \pm 500 / \pm 1000 / \pm 2000dps$		
	Bluetooth	Bluetooth 4.1		
Electrical Features	Working Voltage	9~48V DC		
Environment	Operating Temperature:	-40 °C ~ 85 °C		
	Humidity	95% RH @ 50 °C non-condensing		
	ESD	IEC 61000-4-2 (4KV test)		
Battery parameter	Capacity	1200mAh		
	Battery Material	Ni-MH		
	Working Temperature	Charging: 0 ~ 45 °C; Discharging: -40 ~ 85 °C		
	Storage Temperature	For 1 month: -40 °C ~ 55 °C; For 1 year: -40 ~ 35 °C		
Mechanical Features	Shell Material	Engineering plastic + engineering plastic alloy (PC + ABS)		
	Dimensions	Approximately 158 x 100 x 44 mm		
	Protection Rating	IP66		
Vehicle Features	CANBus	2 channels		
	J1708/RS485	1 channel	Serial Port	RS232
I/O	Ignition Signal	1 channel		
	Digital Input	4 channels	Digital Output	3-channels (max. 300 mA)
	1-Wire	1 channel, 4 sensor	Analog Input	1 channel
External Interfaces	SIM Card Slot	2FF, push-in slot		
	I/O	26 PIN		
	LED Indicator	2 LED indicators: cellular status, GNSS status		
Software Service	Cloud platform	AWS IoT、Azure IoT、Aliyun IoT、Wialon、Traccar、GPSWox、WhiteLable Tracking、Thingsboard、Customer platform		
	Transport protocol	TCP、UDP、HTTP、MQTT		
	Vehicle Data	OBDII、J1939、J1708		
	RS232/RS485	Transparent、Modbus protocol data acquisition		
	Event Alarm	Collision detection、Motion detection、Overspeed、IO change、ignition signal detection etc.		
		Report support SMS or FlexAPI over TCP/UDP/MQTT		
Config	ELD	Forward vehicle data via BLE		
	Configuration Tool	RS232 or Bluetooth		
Certification* (In progress)	CE、FCC、IC、PTCRB、E-Mark、AT&T、Verizon			

Ordering Guide

Model	Cellular Type	Region
VT320-FQ33	LTE CAT1: LTE-FDD B2/B4/B5/B12/B13 WCDMA B2/B4/B5	North America
VT320-FQ02	LTE Cat M1: LTE-FDD: B1/B2/B3/B4/B5/B8/B12/B13/ B14/B18/ B19/B20/B25/B26/B27/ B28/B66/B85 LTE Cat NB2: LTE-FDD: B1/B2/B3/B4/B5/B8/B12/B13/ B18/B19/ B20/B25/B26/ B28/B66/B71/B85 EGPRS: 850/900/1800/1900 MHz	Global

Accessories

Cable	Picture	Order Code	Specifications
26 PIN Test Cable			The cable has P1 and P2 ends: P1 is 26PIN female, connected to VT320; P2 is open end, which requires a 9-48V adaptor. Suitable for engineering environments and indoor tests.

About Us

InHand Networks is a global leader of Industrial IoT, with a record of tremendous success following groundbreaking innovation since our inception in 2001.

InHand serves world-class partners and customers with industrial M2M routers, gateways, industrial Ethernet switches, rugged computers and IoT management platforms. We provide IoT solutions for various vertical markets including Smart Grid, Industrial Automation, Remote Machine Monitoring, Smart Vending, Smart City, Retail and more.

Proudly bearing the marks of both Rockwell Automation Encompass Product Partner in Asia-Pacific and Schneider Electric CAPP Technology Partner, InHand Networks defines industrial innovation and reliability.



43671 Trade Center Place, Suite 100, Dulles, VA 20166, USA

T: +1 (703) 348-2988

E: info@inhandnetworks.com

www.inhandnetworks.com

