

PP-RJ-...

Patch panels

Data sheet
107962_en_01

© PHOENIX CONTACT 2018-12-18



1 Description

The component is an Ethernet patch panel for DIN rail mounting. It represents the transition of the field cabling to the internal control cabinet cabling.

The connection from the patch panel to the end device is ensured with a prefabricated patch cable via the RJ45 socket (CAT5e).

Features

- 10/100/1000 Mbps
- Mounting on a DIN rail
- Safe shield connection to ground potential
- Various connection options depending on the product version
 - RJ45 socket
 - Screw terminal blocks
 - Push-in connection
 - IDC connection



Make sure you always use the latest documentation.
It can be downloaded from the product at phoenixcontact.net/products.



The PP-RJ... patch panels are compatible with the devices of the FL-PP... product family.
When replacing FL-PP... devices with PP-RJ... devices, strip an additional 1.4 cm of the cable sheath away.

2	Table of contents	
1	Description	1
2	Table of contents	2
3	Ordering data	3
4	Technical data	6
5	Safety regulations and installation notes.....	8
	5.1 Installation in Zone 2.....	8
	5.2 UL notes.....	9
6	Product description.....	10
	6.1 Function elements	11
7	Installation	12
	7.1 Mounting	12
	7.2 Removal.....	12
	7.3 RJ45 interface	12
	7.4 Terminal assignment	13
	7.5 Stripping.....	13
	7.6 Screw terminal blocks (only PP-RJ-SC).....	13
	7.7 Push-in terminal blocks (only PP-RJ-SCC).....	13
	7.8 IDC terminal blocks (only PP-RJ-IDC)	14
	7.9 Shield contacting with strain relief	14

3 Ordering data

Description	Type	Order No.	Pcs./Pkt.
Patch panel, two RJ45 sockets, 10/100/1000 Mbps, DIN rail mounting, IP20	PP-RJ-RJ	2703015	1
Patch panel, RJ45 socket on screw terminal blocks, 10/100/1000 Mbps, DIN rail mounting, IP20, shield contacting with strain relief	PP-RJ-SC	2703016	1
Patch panel, RJ45 socket on Push-in terminal blocks, 10/100/1000 Mbps, DIN rail mounting, IP20, shield contacting with strain relief	PP-RJ-SCC	2703018	1
Patch panel, RJ45 socket on IDC terminal blocks, 10/100/1000 Mbps, DIN rail mounting, IP20, shield contacting with strain relief	PP-RJ-IDC	2703019	1
Accessories	Type	Order No.	Pcs./Pkt.
Patch panel, two RJ45 sockets, 10/100/1000 Mbps, DIN rail mounting, IP20, shield current monitoring, surge protection	PP-RJ-RJ-F	2703020	1
Patch panel, RJ45 socket on screw terminal blocks, 10/100/1000 Mbps, DIN rail mounting, IP20, shield contacting with strain relief, shield current monitoring, surge protection	PP-RJ-SC-F	2703021	1
Patch panel, RJ45 socket on Push-in terminal blocks, 10/100/1000 Mbps, DIN rail mounting, IP20, shield contacting with strain relief, shield current monitoring, surge protection	PP-RJ-SCC-F	2703022	1
Patch panel, RJ45 socket on IDC terminal blocks, 10/100/1000 Mbps, DIN rail mounting, IP20, shield contacting with strain relief, shield current monitoring, surge protection	PP-RJ-IDC-F	2703023	1
Crimping pliers, for assembling the RJ45 plugs FL PLUG RJ45..., for assembly on site	FL CRIMPTOOL	2744869	1
CAT5-SF/UTP cable (J-02YS(ST)C HP 2 x 2 x 24 AWG), heavy-duty installation cable, 2 x 2 x 0.22 mm ² , solid conductor, shielded, outer sheath: 7.8 mm diameter, inner sheath: 5.75 mm ±0.15 mm diameter cable, Ethernet CAT5 (100 Mbps), 4-position, halogen-free compound, HM 2 in acc. with VDE 0207, water blue RAL 5021, cable length: Free input (0.25 ... 1000.0 m)	FL CAT5 HEAVY	2744814	1
CAT5-SF/UTP cable (J-02YS(ST)C HP 2 x 2 x 24 AWG), heavy-duty installation cable, 2 x 2 x 0.22 mm ² , solid conductor, shielded, outer sheath: 7.8 mm diameter, inner sheath: 5.75 mm ±0.15 mm diameter, preassembled on both sides with RJ45 plug, crossover or line, network cable, number of positions: 4, 100 Mbps, CAT5	FL CAT5 HEAVY CONF/	2744827	1

Accessories	Type	Order No.	Pcs./Pkt.
CAT5-SF/UTP cable (J-LI02YS(ST)C H 2 x 2 x 26 AWG), light-duty, flexible installation cable 2 x 2 x 0.14 mm ² , stranded, shielded, outer sheath: 5.75 mm ±0.15 mm diameter	FL CAT5 FLEX	2744830	1
CAT5-SF/UTP cable (J-LI02YS(ST)C H 2 x 2 x 26 AWG), light-duty, flexible installation cable 2 x 2 x 0.14 mm ² , stranded, shielded, outer sheath: 5.75 mm ±0.15 mm diameter, preassembled on both sides with RJ45 plug, crossover or line assignment, network cable, number of positions: 4, 100 Mbps, CAT5	FL CAT5 FLEX CONF/	2744843	1
Actuation tool, for ST terminal blocks, also suitable for use as a bladed screwdriver, size: 0.4 x 2.5 x 75 mm, 2-component grip, with non-slip grip	SZF 0-0,4X2,5	1204504	10
Passive network isolator for electrical isolation in Ethernet networks. This protects Ethernet devices from potential differences of up to 4 kV. Can be used for transmission speeds of up to 100 Mbps. Connection using RJ45 and COMBICON plug-in screw terminal block.	FL ISOLATOR 100-RJ/SC	2313928	1
Passive network isolator for electrical isolation in Ethernet networks. This protects Ethernet devices from potential differences of up to 4 kV. Can be used for transmission speeds of up to 100 Mbps. Possible to connect two RJ45 plugs.	FL ISOLATOR 100-RJ/RJ	2313931	1
Passive network isolator for electrical isolation in Ethernet networks. This protects Ethernet devices from potential differences of up to 4 kV. Can be used for transmission speeds of up to 1 Gbps. Possible to connect two RJ45 plugs.	FL ISOLATOR 1000-RJ/RJ	2313915	1
Passive network isolator for electrical isolation in Ethernet networks. For the protection of Ethernet devices against potential differences of up to 4 kV. Can be used for transmission speeds of up to 100 Mbps. Ethernet connection via two M12 sockets (D-coded).	FL ISOLATOR 100-M12	2902985	1
Patch cable, CAT5, assembled, 0.3 m	FL CAT5 PATCH 0,3	2832250	10
Patch cable, CAT5, assembled, 0.5 m	FL CAT5 PATCH 0,5	2832263	10
Patch cable, CAT5, assembled, 1 m	FL CAT5 PATCH 1,0	2832276	10
Patch cable, CAT5, assembled, 1.5 m	FL CAT5 PATCH 1,5	2832221	10
Patch cable, CAT5, assembled, 2 m	FL CAT5 PATCH 2,0	2832289	10
Patch cable, CAT5, assembled, 3 m	FL CAT5 PATCH 3,0	2832292	10
Patch cable, CAT6, pre-assembled, 0.3 m	FL CAT6 PATCH 0,3	2891181	10
Patch cable, CAT6, pre-assembled, 0.5 m	FL CAT6 PATCH 0,5	2891288	10
Patch cable, CAT6, pre-assembled, 1.0 m	FL CAT6 PATCH 1,0	2891385	10
Patch cable, CAT6, pre-assembled, 1.5 m	FL CAT6 PATCH 1,5	2891482	10
Patch cable, CAT6, pre-assembled, 2.0 m	FL CAT6 PATCH 2,0	2891589	10
Patch cable, CAT6, pre-assembled, 3.0 m	FL CAT6 PATCH 3,0	2891686	10
Patch cable, CAT6, pre-assembled, 5.0 m	FL CAT6 PATCH 5,0	2891783	10

Accessories	Type	Order No.	Pcs./Pkt.
Patch cable, CAT6, pre-assembled, 7.5 m	FL CAT6 PATCH 7,5	2891880	10
Patch cable, CAT6, pre-assembled, 10 m	FL CAT6 PATCH 10	2891877	10
Patch cable, CAT6, pre-assembled, 12.5 m	FL CAT6 PATCH 12,5	2891369	5
Patch cable, CAT6, pre-assembled, 15.0 m	FL CAT6 PATCH 15,0	2891372	5
Patch cable, CAT6, pre-assembled, 20.0 m	FL CAT6 PATCH 20,0	2891576	5
Stripping tool, for the multi-level stripping of shielded cables	VS-CABLE-STRIP-VARIO	1657407	1
RJ45 connector, degree of protection: IP20, number of positions: 8, 1 Gbps, CAT5 (IEC 11801:2002), material: PA, connection method: IDC fast connection, connection cross section: AWG 26- 23, cable outlet: straight, color: traffic grey A RAL 7042	VS-08-RJ45-5-Q/IP20	1656725	1
RJ45 connector, degree of protection: IP20, number of positions: 8, 1 Gbps, CAT5 (IEC 11801:2002), material: PA, connection method: IDC fast connection, connection cross section: AWG 26- 23, cable outlet: straight, color: black	VS-08-RJ45-5-Q/IP20 BK	1658008	1
Actuation tool, for ST terminal blocks, also suitable for use as a bladed screwdriver, size: 0.4 x 2.5 x 75 mm, 2-component grip, with non-slip grip	SZF 0-0,4X2,5	1204504	10
Electronic diagonal cutter , tapered head, angled (21°), without chamfer, with opening spring Diagonal cutter	MICROFOX-SP	1212488	1
Network cable, Ethernet CAT6 _A (10 Gbps), 8-position, PUR halogen-free, water blue RAL 5021, shielded, free cable end, on free cable end, cable length: Free entry (0.5 ... 400 m)	VS-OE-OE-94F/...	1417359	1

4 Technical data

Ethernet interface, 10/100/1000Base-T(X) according to IEEE 802.3u	PP-RJ-RJ	PP-RJ-SC	PP-RJ-SCC	PP-RJ-IDC
Connection method	RJ45 socket	Screw terminal block	Push-in connection	IDC connection
Conductor cross section, flexible		0.14 mm ² ... 1.5 mm ²	0.2 mm ² ... 1.5 mm ²	0.14 mm ² ... 0.34 mm ²
Conductor cross section, flexible [AWG]		28 AWG ... 16 AWG	26 AWG ... 16 AWG	26 AWG ... 22 AWG
Conductor cross section, solid		0.14 mm ² ... 1.5 mm ²	0.2 mm ² ... 1.5 mm ²	0.14 mm ² ... 0.34 mm ²
Stripping length		5 mm	8 mm	
Pin assignment	1:1	1:1	1:1	1:1
Torque		0.22 Nm ... 0.25 Nm		
Wire diameter incl. insulation				1.6 mm (Terminal block is tested with PVC insulation - other insulation materials available on request)

Ethernet interface, 10/100/1000Base-T(X) according to IEEE 802.3u	
Connection method	RJ45 CAT5e
Maximum output power	60 W
Output nominal voltage	< 60 V (ATEX approval) < 57 V DC (with UL approval)
Maximum output current	725 mA (per channel)
Serial transmission speed	10/100/1000 Mbps
Transmission length	100 m (including patch cables)
Connection line	twisted pair, shielded, CAT5 or better
Pin assignment	1:1

General data	
Degree of protection	IP20 (manufacturer's declaration)
Rated insulation voltage	85 V DC
Mounting type	DIN rail mounting, stationary
Dimensions (W/H/D)	23.8 mm x 101.3 mm x 50 mm
External cable diameter	5.5 mm ... 6.5 mm
Housing material	Plastic gray
Vibration resistance in acc. with EN 60068-2-6/ IEC 60068-2-6	10 Hz ... 57 Hz, amplitude ± 3.5 mm, 57 Hz ... 150 Hz, 5g
Shock in acc. with EN 60068-2-27/IEC 60068-2-27	25g for 11 ms, three shocks in each direction
MTTF (mean time to failure)	105699 Years
Overvoltage category	II
Degree of pollution	2
Ambient conditions	
Ambient temperature (operation)	-40 °C ... 75 °C
Ambient temperature (storage/transport)	-40 °C ... 85 °C
Permissible humidity (operation)	10 % ... 95 % (non-condensing)
Altitude	5000 m (for restrictions see manufacturer's declaration) 2000 m (ATEX approval)
Approvals / Certificates	
Conformance	CE-compliant
ATEX Please follow the special installation instructions in the documentation!	Ⓔ II 3 G Ex nA IIC Gc U
UL, USA	UL 60079-0 Ed. 6 / UL 60079-15 Ed. 4
UL, Canada	CSA 22.2 No. 60079-0 Ed. 3 / CSA 22.2 No. 60079-15:16
Noxious gas test	ISA-S71.04-1985 G3 Harsh Group A

5 Safety regulations and installation notes



CAUTION:

Observe the following safety notes when using the device.

- The category 3 product can be installed in zone 2 potentially explosive areas. It satisfies the demands of the following standards:
 - EN 60079-0
 - EN 60079-15
 - Comprehensive details are to be found in the EU Declaration of Conformity which is enclosed and also available on our website in the latest version.
- Installation, operation, and maintenance may only be carried out by qualified electricians. Follow the installation instructions as described.
- When installing and operating the device, the applicable regulations and safety directives (including national safety directives), as well as the generally recognized codes of practice must be observed. The safety-relevant data is included in this packing slip and on the certificates (manufacturer's declaration, additional approvals where applicable).
- Opening or modifying the product is prohibited. Do not repair the product yourself; replace it with an equivalent product instead. Repairs may only be carried out by the manufacturer. The manufacturer is not liable for damage resulting from non-compliance.
- The IP20 degree of protection (IEC 60529/EN 60529) of the product is intended for a clean and dry environment. Do not subject the product to mechanical and/or thermal stress that exceeds the specified thresholds.
- The product is not designed for use in potentially dust-explosive atmospheres.
- The product must be stopped and immediately removed from the Ex area if it is damaged, has been subjected to an impermissible load, stored incorrectly, or if it malfunctions.

5.1 Installation in Zone 2



WARNING: Explosion hazard when used in potentially explosive areas

Please make sure that the following notes and instructions are observed.

- Only devices that are designed for operation in Ex Zone 2 and the conditions at the installation location may be connected to the circuits in Zone 2.
- Connecting and disconnecting cables in the potentially explosive area and snapping devices onto and off of the DIN rail is only permissible in a de-energized state or when it has been ensured that an explosive atmosphere is not present.
- For safe operation, lockable plug connections must have a functional interlock (e. g. locking clip, screw connection etc.). Insert the interlock. Repair any damaged connectors immediately.
- Use a transient protection system which limits the interference voltage to a maximum of 140% of the rated voltage.
- The DIN rail must be connected to protective ground.

5.2 UL notes



WARNING: Explosion hazard when used in potentially explosive areas

Please make sure that the following notes and instructions are observed.



IND. CONT. EQ., ALSO
LISTED IND. CONT.
EQ. FOR HAZ. LOC.
E366272



U = max. 57 V DC

P = max. 60 W

Amb. Temp.: $-40^{\circ}\text{C} < T_a < 75^{\circ}\text{C}$

Class I, Zone 2, AEx nA IIC T4, Ex nA IIC Gc X T4

Class I, Division 2, Groups A, B, C and D

INDUSTRIAL CONTROL EQUIPMENT FOR HAZARDOUS LOCATIONS

- A) This equipment must be mounted in an enclosure certified for use in Class I, Zone 2 minimum and rated IP54 minimum in accordance with IEC 60529 when used in Class I, Zone 2 environment.
- B) Device shall only be used in an area of not more than pollution degree 2.
- C) If the equipment is used in a manner not specified, the protection provided by the equipment may be impaired.
- D) Minimum temperature rating of the cables to be connected to the field wiring terminals: 80°C
- E) The external circuits connected to the terminal of the device must be supplied from SELV/PELV.
- F) The device has to be built in the final safety enclosure, which has adequate rigidity according to UL 61010-1, UL 61010-2-201 and meets the requirements with respect to spread of fire.
- G) Use copper conductors only.

6 Product description

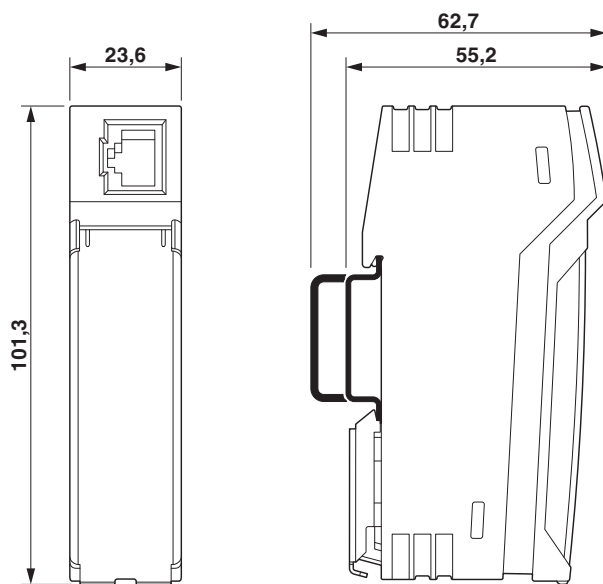

Figure 1 Dimensions

PP-RJ-RJ

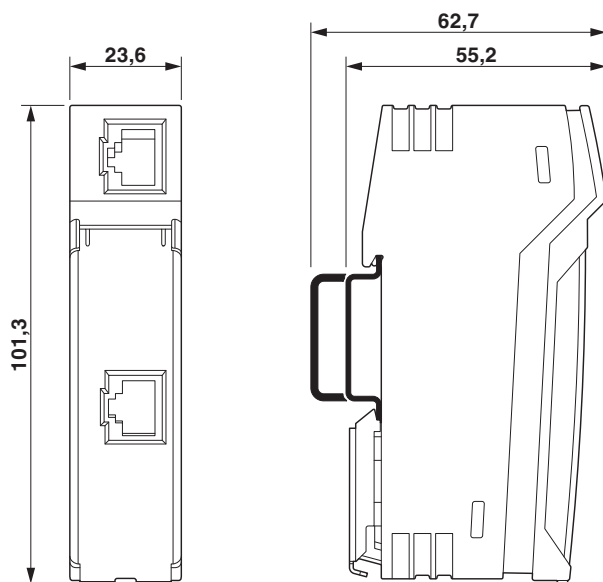

Figure 2 Dimensions

6.1 Function elements

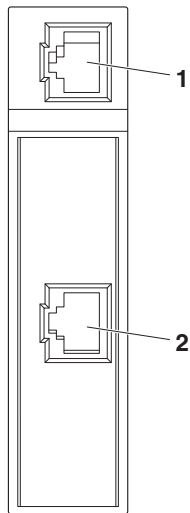

Figure 3 PP-RJ-RJ

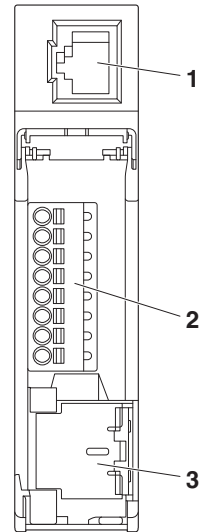

Figure 5 PP-RJ-SCC

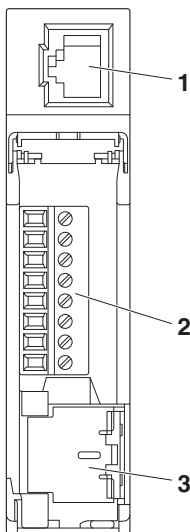

Figure 4 PP-RJ-SC

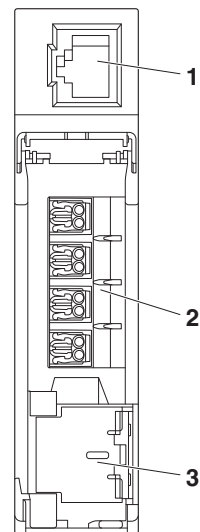

Figure 6 PP-RJ-IDC

- 1 X1 Shielded RJ45 socket (TP port)
- 2 X2 Port 2 depending on product version, see above
- 3 Shield contact spring (shield contacting with strain relief)

7 Installation



WARNING: Explosion hazard when used in potentially explosive areas

Only mount or remove the device when disconnected from the voltage!

7.1 Mounting

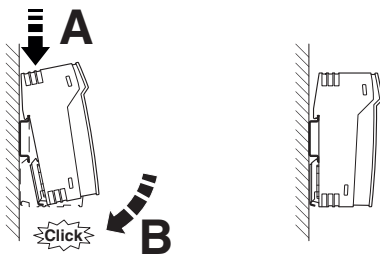

Figure 7 Mounting on a DIN rail

The device is intended for installation in a control cabinet.

- Connect a 35 mm EN DIN rail to the protective earth via a grounding terminal block. The device is grounded by snapping it onto the DIN rail.
- Snap the device onto the DIN rail.

7.2 Removal

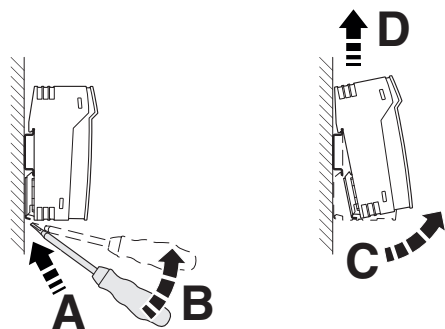

Figure 8 Removal

- Push down the locking tab with a screwdriver, needle-nose pliers or similar.
- Slightly pull the bottom edge of the device away from the mounting surface.
- Pull the device away from the DIN rail.

7.3 RJ45 interface



NOTE: Interference

Only use shielded twisted pair cables and corresponding shielded RJ45 connectors.

- Only twisted pair cables with an impedance of 100 Ω can be connected to the RJ45 Ethernet interface.
- Insert the Ethernet cable with the RJ45 plug into the TP interface until the plug engages audibly. Observe the plug keying.

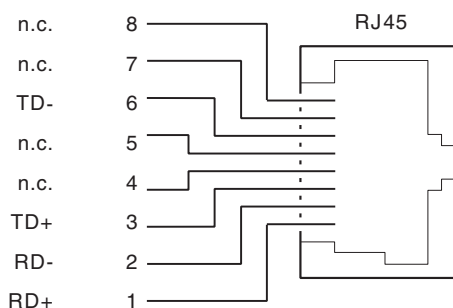

Figure 9 Pin assignment

7.4 Terminal assignment

Terminal assignment for Ethernet (IEC 80.3u: TIA 568 A, TIA 568 B) and PROFINET

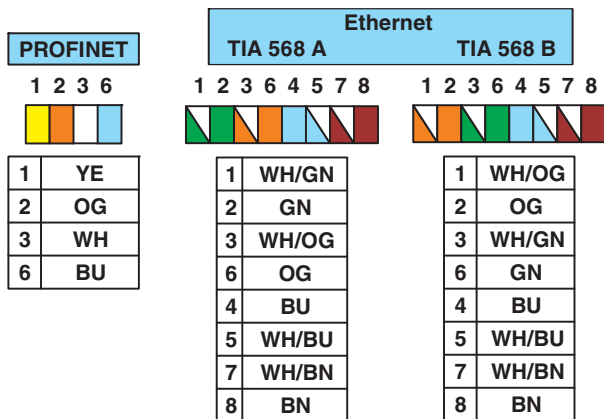

Figure 10 Terminal assignment

Key:

- OG Orange
- WH White
- GN Green
- YE Yellow
- BU Blue
- BN Brown

7.5 Stripping

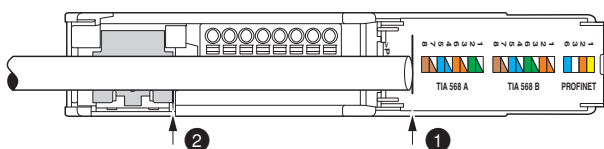

Figure 11 Length for stripping

You can quickly determine the crimping length for the product versions with connection terminal blocks:

- Open the cover.
- Place the cable end on the marking line ①.
- The edge of the shield contact spring ② indicates the correct length for stripping (5.5 cm).
- Strip the cable.
- Keep the aluminum foil on the single wires as far as possible.
- Fold back 20 mm of the braided shield backwards over the outer sheath.

7.6 Screw terminal blocks (only PP-RJ-SC)

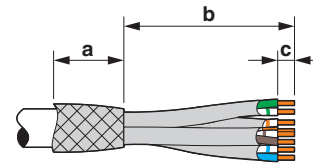

Figure 12 Stripping specifications

- a 20 mm
- b 55 mm
- c 5 mm

- Strip off each individual wire to 5 mm.
- If possible, make sure that the individual wires remain twisted up to the terminal blocks.
- Connect the single wires to the terminal blocks.

7.7 Push-in terminal blocks (only PP-RJ-SCC)

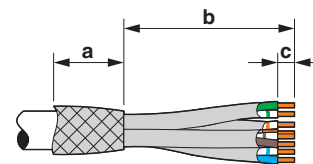

Figure 13 Stripping specifications

- a 20 mm
- b 55 mm
- c 8 mm

- Strip off each individual wire to 8 mm.
- If possible, make sure that the individual wires remain twisted up to the terminal blocks.
- Connect the single wires to the terminal blocks.

7.8 IDC terminal blocks (only PP-RJ-IDC)

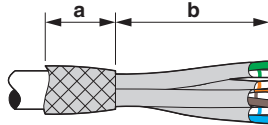

Figure 14 Stripping specifications

- a 20 mm
- b 55 mm

- Open the connection terminal blocks.
- If possible, make sure that the individual wires remain twisted up to the terminal blocks.
- Insert the single wires into the connection terminals as far as they will go.
- Snap in the terminal blocks.

7.9 Shield contacting with strain relief

The product versions with connection terminal blocks are equipped with built-in strain relief and shielding braid.

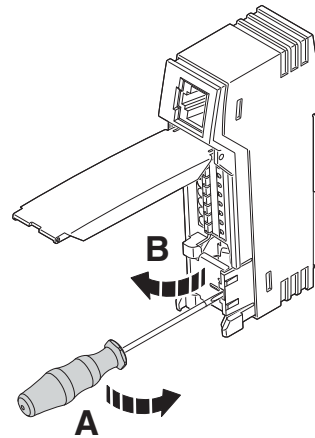

Figure 15 Open shield contact spring

- Open the shield contact spring.
- If the spring is latched in place, use a screwdriver to open it.

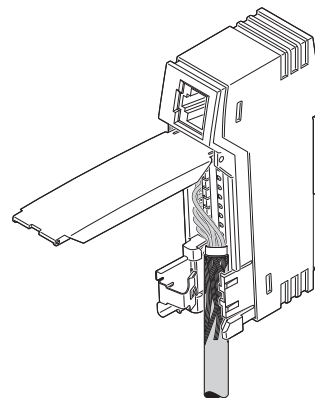

Figure 16 Inserting the cable

- Place the cable with the folded braided shield into the guiding shaft.

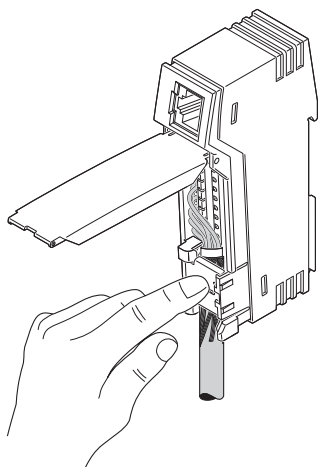

Figure 17 Close shield contact spring

- Snap in the shield contact spring. The braided shield is pressed against the left side of the guiding shaft. This establishes the shield contacting.
- Organize the wires so that you can close the cover.



Fully snap in the foldable cover to prevent unintentional opening.