

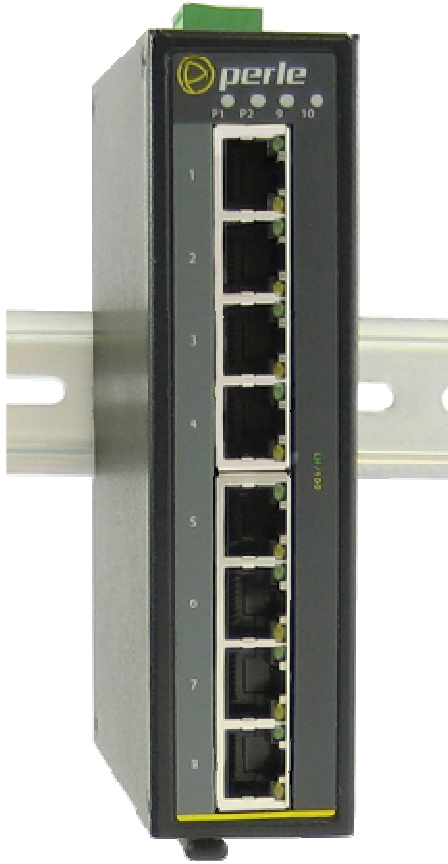

Perle IDS-108F(XT)

Unmanaged 10/100
Ethernet Switches



Installation Guide

Overview

This document contains instructions necessary for the installation and operation of the Perle IDS-108F Ethernet switch. This Ethernet switch can be ordered as an 8-port RJ-45 switch or as an 8-port RJ-45 switch with one or two SC or ST fiber ports. The fiber ports can be either single mode (SM) or multimode (MM) depending on the model selected and they can operate over different wavelengths and distances. Visit the Perle website for the most up to date installation guides, models and specifications.

<http://www.perle.com/>

Model	Port 1-8	Port 9 and 10
IDS-108F	TP (RJ-45)	empty
IDS-108F-xxxxxxx	TP (RJ-45)	1 or 2 fiber ports
IDS-108F-XT (Industrial Temperature Model)	TP (RJ-45)	empty
IDS-108F-xxxxxxx-XT (Industrial Temperature Model)	TP (RJ-45)	1 or 2 fiber ports

Note: xxxxxxxx indicates models numbers for this product line.

TP = twisted pair

XT – Extended Temperature models

Features

- 10/100Base-TX, one or two ST/SC fiber ports, multi/single mode
- IEEE 802.3/802.3u/802.3x
- 10/100, Full/Half duplex, MDI/MDIX with auto-sensing
- Auto-negotiation on copper ports
- Redundant DC power inputs
- Rugged high-strength case
- Industrial temperature models
- Din-rail or wall/panel mounting

Note – In this guide the various models will be referred to as the IDS-108F

Getting to know your IDS-108F Switch

Package Contents:

- IDS-108F
- DIN-rail mounting clip (pre-installed on the unit)
- This guide

Note – Optional panel/wall mounting kits may be ordered for the IDS-108F

Front View of IDS-108F (8 port RJ-45)

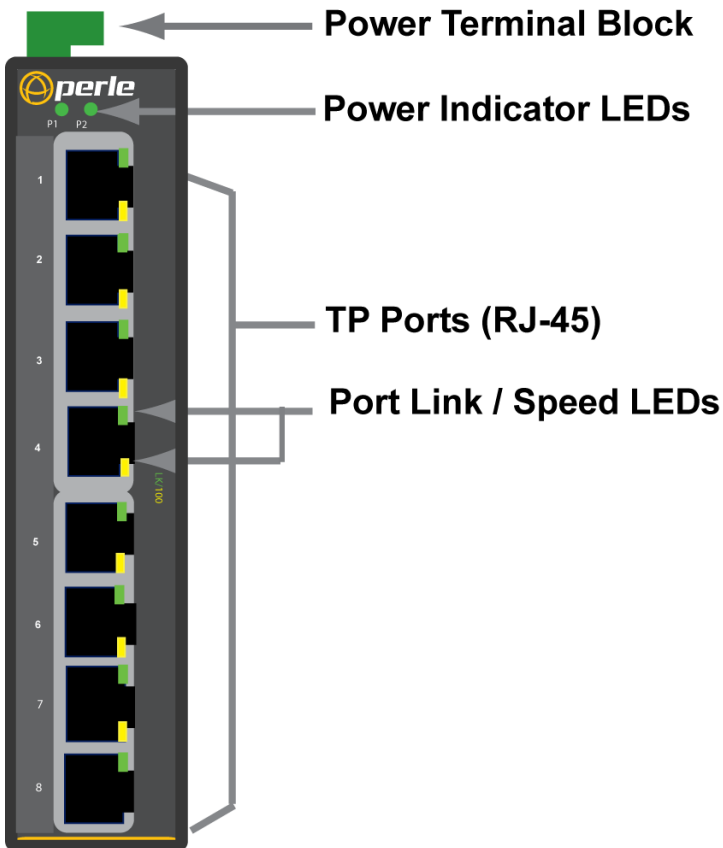

Front View of IDS-108F (with two Fiber ports)

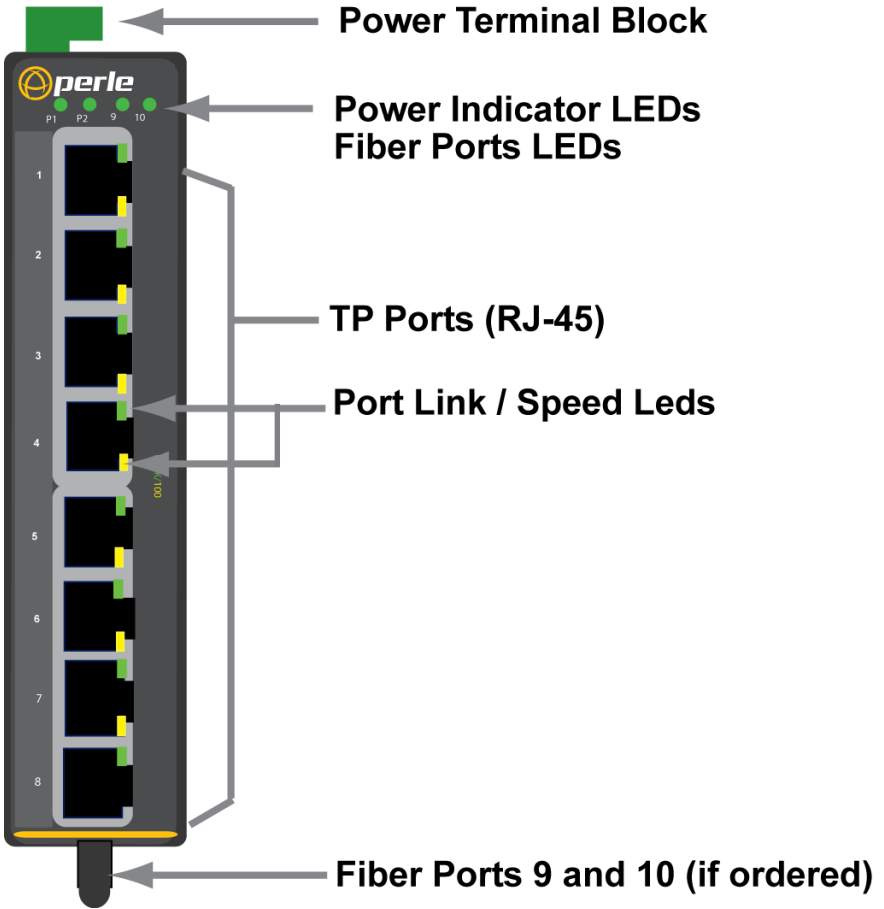

Bottom view of the IDS-108F (with two ST fiber ports)

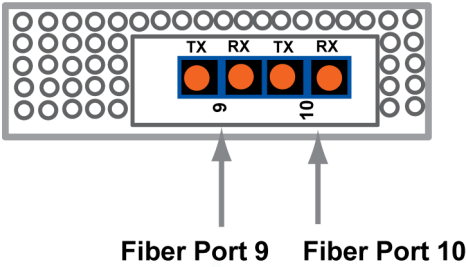

Top view of the IDS-108F

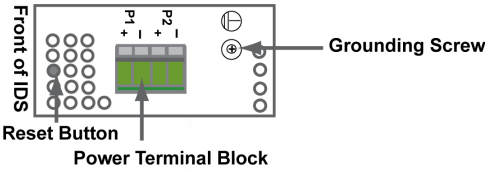

Specifications

Terminal block Header (J1) – Cat. No. 5EHDR-04P, manufactured by Dinkle Enterprise Co., Ltd. Rated 300 V, 15 A, 105°C, FW-1.

Terminal block Plug – Cat. No. 5ESDV-04P, manufacturing by Dinkle Enterprise Co., Rated 300 V, 105°C, FW-2, suitable for 28-12 AWG (0.0804-3.31 mm2), torque value 4.5 lb-in.

Power

The IDS-108F switch has two power inputs that can be connected simultaneously to DC or AC power sources. If one power source fails, the other acts as a backup, and automatically powers the switch.

Reset Button

To reset the IDS-108F insert a paper clip into the air hole vent and gently press the reset button. The LEDs on the IDS-108F will go On and then momentarily Off when released to show that the unit has been reset. All links will be dropped and the MAC tables will be cleared.

Status LED (with two fiber ports)

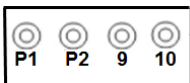

P1 / P2– Power (Green LED)

On: Power present

Off: No Power present

Fiber Port 9/10 (Green LED)

On: Link up

Flashing: Link up and Ethernet activity detected

Off: Link down

Ethernet Port Status



Port Link / Speed (Green and Yellow LEDs)

On: Link Up

- 100 Mbps Yellow on
- 10 Mbps Yellow off

Flashing: Link up and Ethernet activity detected

Off : Link down

Dimensions for the IDS-108F

Top View

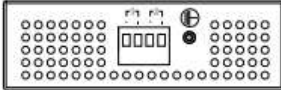

Front View

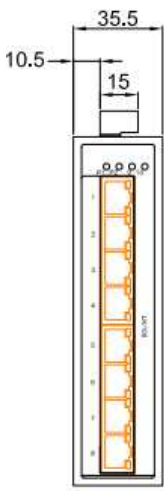

RJ45 Models

Side View

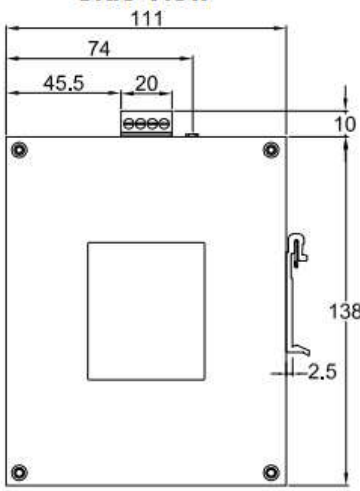

Back View

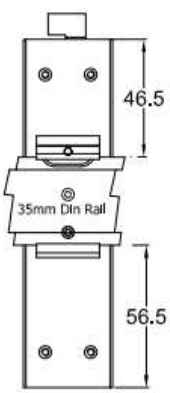

Bottom View

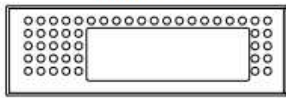

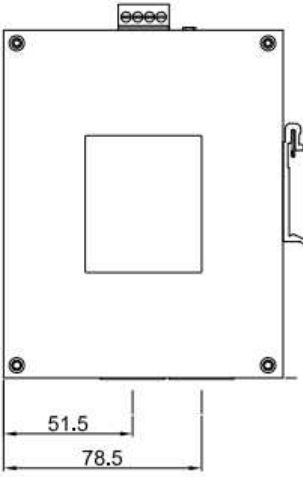

SC Models

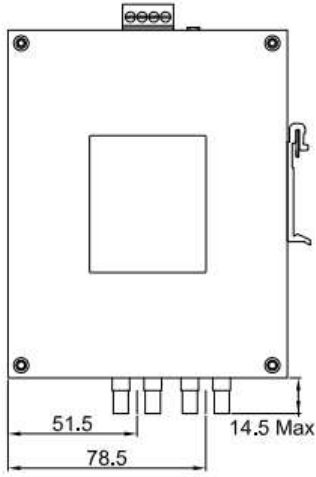
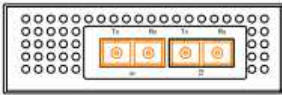

ST Models

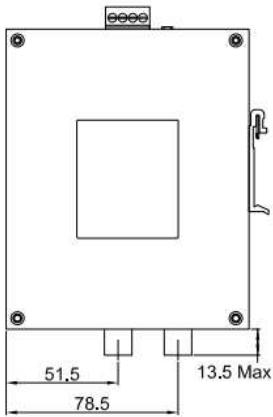
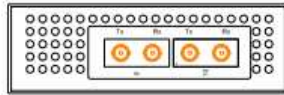

Single Fiber Models



Mounting the IDS-108F on a DIN-rail

1. The DIN-rail clip will be fixed to the back panel of the IDS-108F switch when you receive the product.
2. Position the IDS-108F such that the top of the DIN rail fits into the slot on the top of the DIN-rail clip, just below the DIN-rail hook and behind the spring.
3. While pushing down on the unit to compress the spring, rotate the bottom of the IDS-108F toward the rail. This will snap the bottom of the rail into the bottom of the clip. See diagram below.

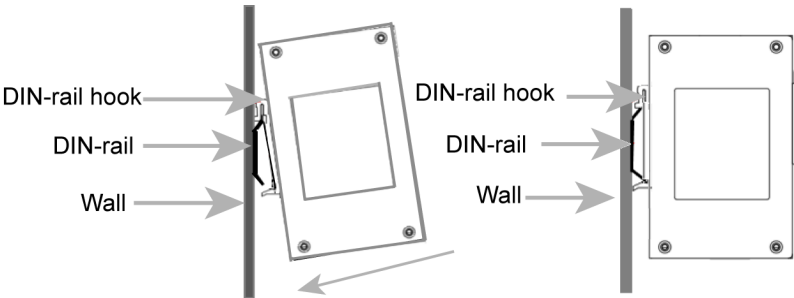

Note: To remove the IDS-108F from the DIN-rail, push down slightly on the IDS-108F unit while pulling the bottom out.

Wall Mounting the IDS-108F

1. Remove the DIN-rail clip from the rear panel on the IDS-108F.
2. Attach the wall mount plates to the IDS-108F as shown below using the screws provided in the kit.

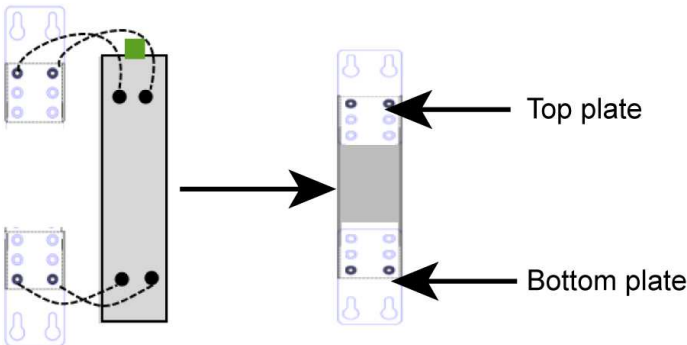

3. Use the wall mount plates as a guide to mark the spots where the screws will be.
4. Drive the screws into the wall leaving about 2 mm of the screw protruding from the wall to allow room for sliding the wall mount panel between the wall and the screws.
5. Once the screws are fixed to the wall, insert the four screw heads through the large parts of the keyhole shaped screw openings.
6. Pull the IDS down to lock the IDS-108F to the wall mount.
7. Tighten the four screws securely to the wall.

Note: For the best results use screws that have the following attributes:
Head diameter .5 - .6 mm
Shaft diameter 3 - 3.5 mm

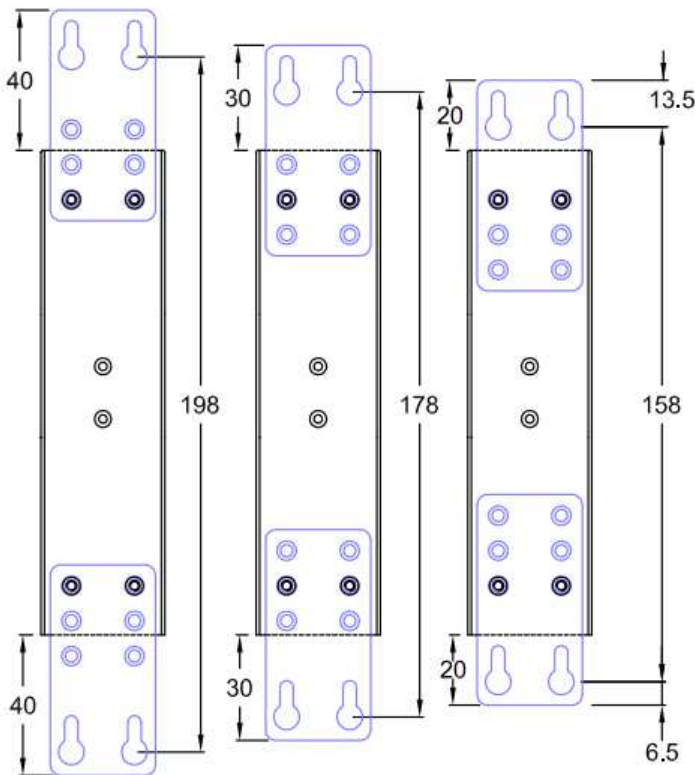

Note: the dimensions are in mm

Wiring up the IDS-108F



Power sources must be off prior to beginning the power connection steps.



Ensure that the voltage and current ratings of the intended power source are appropriate for the IDS-108F as indicated on the product label.



Ensure that the installation and electrical wiring of the equipment is performed by trained and qualified personnel and that the installation complies with all local and national electrical codes



If this unit is to be installed in a location where the ambient temperature exceeds 50C, the case temperature may exceed safe levels. For this reason, this unit should be installed in a restricted access location where access can only be gained by service personnel or users who have been instructed about the reasons for the restrictions applied to the location and about any precautions that shall be taken; and access is through the use of a tool or lock and key, or other means of security, and is controlled by the authority responsible for the location.

Hazardous Location Warnings

(safe conditions for use:)



The equipment shall be installed in an enclosure that provides a degree of protection not less than IP 54 in accordance with IEC/EN 60079-15 and only accessible by the use of a tool.



Subject devices are for use in an area of not more than pollution degree 2 in accordance with IEC 60664-1.



These devices are open-type devices that are to be installed in an enclosure with tool removable cover or door, suitable for the environment.



This equipment is suitable for use in Class I, Division 2, Groups A,B,C,D or non hazardous locations only.



WARNING –EXPLOSION HAZARD – Do not disconnect equipment unless power has been removed or the area is known to be non-hazardous



WARNING EXPLOSION HAZARD – Substitution of any components on this switch may impair suitability for Class I, Division 2.



Transient protection shall be provided that is set at a level not exceeding 140% of the peak rated voltage value at the supply terminals to the equipment.

Connecting the IDS-108F to ground

If your installation requires additional grounding follow this procedure.

1. Select and obtain an appropriate grounding lug that can be affixed to the ground screw on the top of the IDS-108F.
2. Follow the grounding lug manufacturer's instructions for attaching it to the ground wire.
3. Attach the grounding lug to the chassis and secure with the grounding screw provided.

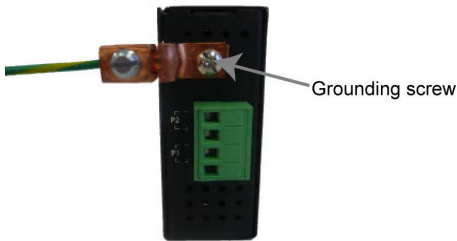

Grounding the chassis requires the following items:

- One grounding lug (not provided)
- One 12 AWG wire (not provided)

Connecting Power to the IDS-108F

1. Ensure the power source is off prior to connection.
2. Strip both (12-20 AWG/3.31-0.518 mm²) wires 5mm (3/16th inch).
3. Loosen the terminal block screws and connect positive (+) / negative (-) wires into the -/+ terminals.
4. Tighten terminal screws (Torque 4.5 lb-in).
5. Ensure the wires are securely fastened.
6. Re-insert the Terminal block connector if removed.
7. Turn on power source.
8. Check that the P1 LED is On.
9. If desired connect P2 (power source 2, beginning again at Step 1).
10. One individual conductor for each clamping point.

Ethernet Copper Cabling Requirements

- Category 5 UTP or STP
- 24-22 AWG
- Straight through or Ethernet crossover cable

Connect the copper cables from each TP port (RJ-45) on the IDS 108F switch to Ethernet-enabled devices. See below for pinouts and cable wire diagrams.

Fiber Port Cabling Requirements

MM: 50/125 microns or 62.5/125 microns

SM: 9/125 microns

Connect the fiber cable to Port 9 and Port 10 (if installed) on the IDS-108F and the other end to a compliant fiber device. If you are making your own fiber cables, remember that the RX on one side needs to go to TX on the other side and vice versa. See diagram below.

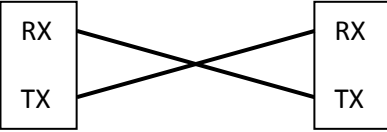

Technical Specifications

Connection	
Dual input terminal block power 8 port Ethernet	Power Input/Consumption 9.6 to 60 VDC, 0.5A max 18 to 30 VAC, 0.4A max
Dual input terminal block power 8+1 fiber port	Power Input/Consumption 9.6 to 60 VDC, 0.7A max 18 to 30 VAC, 0.5A max
Dual input terminal block power 8 + 2 fiber ports	Power Input/Consumption 9.6 to 60 VDC, 0.9A max 18 to 30 VAC, 0.7A max
Reverse Polarity Protection	Yes
Interface	
RJ-45	10/100Base-TX, auto negotiation speed F/H duplex mode and auto MDI/MDI-X
Fiber Ports	One or two SC/ST fiber ports
LED indicators	P1 – power 1, P2 – power 2 Ports 1 – 8 G/Y – Link/Activity/Speed Port 9/10 – port status (Fiber models only)
Environmental	
Operating Temperature Commercial Models (IDS-108F) Industrial Models (IDS-108F-XT)	0°C to 60°C (32°F to 140°F) -40°C to 75°C (-40°F to 167°F)
Storage Temperature Commercial Models (IDS-108F) Industrial Models (IDS-108F-XT)	-25°C to 70°C (-13°F to 158°F) -40°C C to 85°C (-40°F to 185°F)
Operating Humidity	5% to 90% non-condensing
Storage Humidity	5% to 95% non-condensing
Operating Altitude	Up to 3,048 m (10,000 ft)
Regulatory Approvals	
Safety	cUL 60950-1, EN 60950-1
Industrial	UL 508
Hazardous Locations	ANSI/ISA 12.12.01-2013 Class I Division 2 Groups A-D ATEX Class I Zone 2 CENELEC EN 60079-0:2012+A11:2013 CENELEC EN 60079-15:2010 IEC 60079-0 Edition 6 – Revision Date 2012-11-01 IEC 60079-15 – Edition 4 – Issue Date 2010-01-01
Laser Safety	Transmitters: EN60825-1:2007 FDA/CDRH 21 CFR1040.11/CFR1040.11
EMI/EMC	FCC Part 15 – Class A CISPR 22:2008 / EN55022:2010 Class A CISPR 24:2010 / EN55024:2010

Fiber Specifications

IDS-108F models	Fiber Connector	Mode	Distance	Wavelength (nm)	TX Power (dB)	RX Power (dB)	Budget
IDS-108F (XT)	None	n/a	n/a	n/a	n/a	n/a	n/a
IDS-108F-M2SC2 (XT)	SC	MM duplex	2 km 1.2 miles	TX: 1310 RX:1310	Min:-6 Max:-0	Min:-17 Max:-0	11
IDS-108F-M2ST2 (XT)	ST	MM duplex	2 km 1.2)miles	TX: 1310 RX:1310	Min:-6 Max:-0	Min:-17 Max:-0	11
IDS-108F-M1SC2U	SC	MM simplex	2 km 1.2 miles	TX: 1310 RX:1550	Min:-15 Max:-8	Min:-28 Max:-3	13
IDS-108F-M1SC2D	SC	MM simplex	2 km 1.2 miles	TX: 1550 RX:1310	Min:-15 Max:-8	Min:-28 Max:-3	13
IDS-108F-S2SC20 (XT)	SC	SM duplex	20 km 12.4 miles)	TX: 1310 RX:1310	Min:-15 Max:-8	Min:-34 Max:-3	19
IDS-108F-S2ST20 (XT)	ST	SM duplex	20 km 12.4 miles	TX: 1310 RX:1310	Min:-15 Max:-8	Min:-32 Max:-3	17
IDS-108F-S1SC20U (XT)	SC	SM simplex	20 km 12.4 miles	TX: 1310 RX:1490	Min:-8 Max:-3	Min:-22 Max:-2	14
IDS-108F-S1SC20D (XT)	SC	SM simplex	20 km 12.4 miles	TX: 1490 RX:1310	Min:-8 Max:-3	Min:-22 Max:-3	14
IDS-108F-S2SC40 (XT)	SC	SM duplex	40 km 24.9 miles	TX: 1310 RX:1310	Min:-3 Max:-5	Min:-23 Max:-3	20
IDS-108F-S2ST40 (XT)	ST	SM duplex	40 km 24.9 miles	TX: 1310 RX:1310	Min:-3 Max:-5	Min:-23 Max:-3	20
IDS-108F-S1SC40U	SC	SM simplex	40 km 24.9 miles	TX: 1310 RX:1550	Min:-3 Max:2	Min:-23 Max:-3	20
IDS-108F-S1SC40D	SC	SM simplex	40 km 24.9 miles	TX: 1550 RX:1310	Min:-3 Max:2	Min:-23 Max:-3	20
IDS-108F-S2SC80	SC	SM duplex	80 km 49.7 miles	TX: 1550 RX:1550	Min: -5 Max:0	Min:-34 Max: -3	29
IDS-108F-S2ST80	ST	SM duplex	80 km 49.7 miles	TX: 1550 RX:1550	Min: -5 Max: 0	Min:-34 Max: -3	29
IDS-108F-S2SC120	SC	SM duplex	120 km 74.6 miles	TX: 1550 RX:1550	Min:0 Max:5	Min:-32 Max:-9	32
IDS-108F-S2ST120	ST	SM duplex	120 km 74.6 miles	TX: 1550 RX:1550	Min:0 Max:5	Min:-32 Max:-9	32
IDS-108F-DM2SC2 (XT)	2 x SC	MM duplex	2 km 1.2 miles	TX: 1310 RX:1310	Min:-6 Max:-0	Min:-17 Max:-0	11
108F-DM2ST2 (XT)	2 x ST	MM duplex	2 km 1.2 miles	TX: 1310 RX:1310	Min:-6 Max:-0	Min:-17 Max:-0	11
IDS-108F-DM1SC2U	2 x SC	MM simplex	2 km 1.2 miles	TX: 1310 RX:1550	Min:-15 Max:-3	Min:-28 Max:-3	13
IDS-108F-DM1SC2D	2 x SC	MM simplex	2 km 1.2 miles	TX: 1550 RX: 1310	Min:-15 Max:-8	Min:-28 Max:-3	13
IDS-108F-DS2SC20 (XT)	2 x SC	SM duplex	20 km 12.4 miles	TX: 1310 RX:1310	Min:-15 Max:-8	Min:-34 Max:3	19
IDS-108F-DS2ST20 (XT)	2 x ST	SM duplex	20 km 12.4 miles	TX: 1310 RX:1310	Min:-15 Max:-8	Min:-32 Max:-3	17
IDS-108F-DS1SC20U (XT)	2 x SC	SM simplex	20 km 12.4 miles	TX: 1310 RX:1550	Min:-8 Max:-3	Min:-22 Max:-3	14
IDS-108F-DS1SC20D (XT)	2 x SC	SM simplex	20 km 12.4 miles	TX: 1550 RX:1310	Min:-8 Max:-3	Min:-22 Max:-3	14
IDS-108F-DS2SC40 (XT)	2 x SC	SM duplex	40 km 24.9 miles	TX: 1310 RX:1310	Min:-3 Max:-5	Min:-23 Max:-3	20
IDS-108F-DS2ST40 (XT)	2 x ST	SM duplex	40 km 24.9 miles	TX: 1310 RX:1310	Min:-3 Max:-5	Min:-23 Max:-3	20

IDS-108F-DS1SC40U	2 x SC	SM simplex	40 km 24.9 miles	TX: 1310 RX:1550	Min:-3 Max:-2	Min:-23 Max:-3	20
IDS-108F-DS1SC40D	2 x SC	SM simplex	40 km 24.9 miles	TX: 1550 RX:1310	Min:-3 Max:-2	Min:-23 Max:-3	20
IDS-108F-DS2ST80	2 x ST	SM duplex	80 km 49.7 miles	TX: 1550 RX: 1550	Min:-5 Max:0	Min:-34 Max:-3	29
IDS-108F-DS2SC80	2 x SC	SM duplex	80 km 49.7 miles	TX: 1550 RX:1550	Min:-5 Max:0	Min:-34 Max:-3	29
IDS-108F-DS2SC120	2 x SC	SM duplex	120 km 74.6 miles	TX: 1550 RX:1550	Min:0 Max:5	Min:-32 Max:-9	32
IDS-108F-DS2ST120	2 x ST	SM duplex	120 km 74.6 miles	TX: 1550 RX:1550	Min:0 Max:5	Min:-32 Max:-9	32



Model: IDS-108F
P/N: 07010310
S/N: 321-013814T10001



CE FC   

Input: 9.6-60VDC, 0.75A max, Class2
18-30VAC, 50/60Hz, 0.67A max, Class2

DEMKO 14 ATEX 1362X
Ex nA IIC T4 Gc
0°C ≤ Tamb ≤ 60°C
Rated Cable Temp. ≥ 87°C

IND. CONT. EQ. FOR HAZ. LOC.
Class I, Division 2,
Groups A, B, C and D
Temp. Code: T4
Max. Ambient: 60 Deg.C

IND. CONT. EQ.
Max. Surrounding
Air Temp. 60 Deg.C

60 Renfrew Drive,
Markham, Ontario,
Canada. L3R 0E1





Made in Taiwan

For IDS-108F-xxxxxxx





Model: IDS-108F-XT
P/N: 07010640
S/N: 321-343814T10001



CE FC    

Input: 9.6-60VDC, 0.75A max, Class2
18-30VAC, 50/60Hz, 0.67A max, Class2

DEMKO 14 ATEX 1362X
Ex nA IIC T3 Gc
-40°C ≤ Tamb ≤ 75°C
Rated Cable Temp. ≥ 100°C

IND. CONT. EQ. FOR HAZ. LOC.
Class I, Division 2,
Groups A, B, C and D
Temp. Code: T3C
Max. Ambient: 75 Deg.C

IND. CONT. EQ.
Max. Surrounding
Air Temp. 75 Deg.C

60 Renfrew Drive,
Markham, Ontario,
Canada. L3R 0E1

Made in Taiwan

For IDS-108F-xxxxxxx-XT

Contacting Technical Support

Contact information for the Perle Technical Assistance Center (PTAC) can be found at the link below. A Technical Support Query may be made via this web page.

www.perle.com/support_services/support_request.shtml

Warranty / Registration

http://www.perle.com/support_services/warranty.shtml

Copyright © 2014 Perle Systems Limited. All rights reserved. No part of this document may be reproduced or used in any form without written permission from Perle Systems Limited.