

# MGate 5111 Series

## 1-port Modbus/PROFINET/EtherNet/IP to PROFIBUS slave gateways



### Features and Benefits

- Protocol conversion between Modbus, PROFINET, EtherNet/IP, and PROFIBUS
- Supports PROFIBUS DP V0 slave
- Supports Modbus RTU/ASCII/TCP master/client and slave/server
- Supports EtherNet/IP Adapter
- Supports PROFINET IO device
- Effortless configuration via web-based wizard
- Built-in Ethernet cascading for easy wiring
- Embedded traffic monitoring/diagnostic information for easy troubleshooting
- Status monitoring and fault protection for easy maintenance
- microSD card for configuration backup/duplication and event logs
- Supports redundant dual DC power inputs and 1 relay output
- Serial port with 2 kV isolation protection
- -40 to 75°C wide operating temperature models available
- Security features based on IEC 62443

### Certifications



## Introduction

MGate 5111 industrial Ethernet gateways convert data between the Modbus RTU/ASCII/TCP, EtherNet/IP, PROFINET, and PROFIBUS protocols. All models are protected by a rugged metal housing, are DIN-rail mountable, and offer built-in serial isolation.

Modbus is one of the most widely used industrial communication protocols, and EtherNet/IP, PROFINET, and PROFIBUS are commonly used in factory automation and process automation. The MGate 5111 supports both Modbus RTU/ASCII/TCP master and slave modes, so that you can easily connect your Modbus device to PROFIBUS PLCs or DCSs, such as Siemens PLCs.

For system integration, the MGate 5111 can connect to EtherNet/IP PLC/SCADA systems, such as Rockwell Automation PLCs, to PROFIBUS PLC/DCS systems, or between a new Siemens PLC system that supports PROFINET to an existing PROFIBUS system. The MGate 5111 gateways are designed for easy configuration and quick maintenance. A handy web console can be used to implement remote maintenance tasks, and the configuration wizard UI lets you quickly set up your gateway. A comprehensive collection of troubleshooting tools reduce configuration time and system downtime. The rugged design is suitable for industrial applications, such as factory automation, power, oil and gas, water and wastewater, and other process automation industries.

## Easy Configuration

The MGate 5111 Series has a user-friendly interface that lets you quickly set up protocol conversion routines for most applications, doing away with what were often time-consuming tasks in which users had to implement detailed parameter configurations one by one. With Quick Setup, you can easily access protocol conversion modes and finish the configuration in a few steps.

The MGate 5111 supports a web console and Telnet console for remote maintenance. Encryption communication functions, including HTTPS and SSH, are supported to provide better network security. In addition, system monitoring functions are provided to record network connections and system log events.

## A Variety of Maintenance Functions

The MGate 5111 supports Protocol Diagnose and Traffic Monitor for easy troubleshooting, especially during the installation stage. Communication issues caused by incorrect software parameters, such as slave IDs and register addresses, or incorrect command configurations, can be fished out with Protocol Diagnose and Traffic Monitoring, which let you capture and check data to easily identify root causes.

MGate 5111 gateways also support status monitoring and fault protection functions. The status monitoring function notifies a PLC/DCS/SCADA system when a Modbus device gets disconnected or does not respond, in which case the process PLC/DCS gets the status of each end device

and then issues alarms to notify operators. When a PROFIBUS cable gets disconnected, the fault protection function executes actions on end devices identified by a predefined value set by the user.

## Specifications

### Memory

microSD Slot	Up to 32 GB (SD 2.0 compatible)
--------------	---------------------------------

### Relays

Contact Current Rating	Resistive load: 2 A @ 30 VDC
------------------------	------------------------------

### Ethernet Interface

10/100BaseT(X) Ports (RJ45 connector)	2 Auto MDI/MDI-X connection
Magnetic Isolation Protection	1.5 kV (built-in)

### Ethernet Software Features

Industrial Protocols	EtherNet/IP Adapter (Slave), Modbus TCP Client (Master), Modbus TCP Server (Slave), PROFINET IO Device (Slave)
Configuration Options	Device Search Utility (DSU), Web Console, Telnet Console
Management	ARP, DHCP Client, DNS, HTTP, HTTPS, SMTP, SNMP Trap, SNMPv1/v2c/v3, TCP/IP, Telnet, SSH, UDP
MIB	MIB-II
Time Management	NTP Client

### Serial Interface

Console Port	RS-232 (TxD, RxD, GND), 8-pin RJ45 (115200, n, 8, 1)
Baudrate	50 bps to 921.6 kbps
Connector	DB9 male
Data Bits	7, 8
Flow Control	RTS Toggle (RS-232 only), RTS/CTS
Isolation	2 kV (built-in)
No. of Ports	1
Parity	None, Even, Odd, Space, Mark
RS-485 Data Direction Control	ADDC® (automatic data direction control)
Pull High/Low Resistor for RS-485	1 kilo-ohm, 150 kilo-ohms
Serial Standards	RS-232/422/485
Stop Bits	1, 2
Terminator for RS-485	120 ohms

### Serial Signals

RS-232	TxD, RxD, RTS, CTS, DTR, DSR, DCD, GND
RS-422	Tx+, Tx-, Rx+, Rx-, GND

RS-485-2w	Data+, Data-, GND
RS-485-4w	Tx+, Tx-, Rx+, Rx-, GND

### Serial Software Features

Configuration Options	Serial Console
Industrial Protocols	Modbus RTU/ASCII Master, Modbus RTU/ASCII Slave

### Modbus RTU/ASCII

Functions Supported	1, 2, 3, 4, 5, 6, 15, 16, 23
Mode	Master, Slave
Input Data Size	2048 bytes
Max. No. of Commands	128
Output Data Size	2048 bytes

### Modbus TCP

Functions Supported	1, 2, 3, 4, 5, 6, 15, 16, 23
Input Data Size	2048 bytes
Max. No. of Client Connections	16
Max. No. of Commands	128
Max. No. of Server Connections	32
Output Data Size	2048 bytes
Mode	Client, Server

### PROFIBUS Interface

Baudrate	9600 bps to 12 Mbps
Connector	DB9 female
Industrial Protocols	PROFIBUS DP
Isolation	2 kV (built-in)
No. of Ports	1
Signals	PROFIBUS D+, PROFIBUS D-, RTS, Signal Common, 5V

### PROFIBUS

Mode	DP-V0 Slave
Rotary Switch	PROFIBUS addresses 0-99 (addresses 100-125 supported through software configuration)
Input Data Size	244 bytes
Max. No. of Master Connections	1
Max. No. of PROFIBUS I/O Modules	24
Output Data Size	244 bytes

## PROFINET

Input Data Size	512 bytes
Max. No. of IO Controller Connections	1 (for read/write)
Mode	IO Device (Slave)
Output Data Size	512 bytes

## EtherNet/IP

CIP Objects Supported	Identity, Message Router, Assembly, Connection Manager, TCP/IP interface, Ethernet link, Port
Input Data Size	496 bytes
Max. No. of Scanner Connections	1 (for read-only), 1 (for read/write)
Mode	Adapter
Output Data Size	496 bytes

## Power Parameters

Input Current	416 mA @ 12 VDC
Input Voltage	12 to 48 VDC
Power Connector	Spring-type Euroblock terminal

## Physical Characteristics

Housing	Metal
IP Rating	IP30
Dimensions	45.8 x 105 x 134 mm (1.8 x 4.13 x 5.28 in)
Weight	589 g (1.30 lb)

## Environmental Limits

Operating Temperature	Standard Models: 0 to 60°C (32 to 140°F) Wide Temp. Models: -40 to 75°C (-40 to 167°F)
Storage Temperature (package included)	-40 to 85°C (-40 to 185°F)
Ambient Relative Humidity	5 to 95% (non-condensing)

## Standards and Certifications

Safety	EN 60950-1, UL 61010-2-201
EMC	EN 61000-6-2/-6-4
EMI	CISPR 32, FCC Part 15B Class A
EMS	IEC 61000-4-2 ESD: Contact: 8 kV; Air: 15 kV IEC 61000-4-3 RS: 80 MHz to 1 GHz: 10 V/m IEC 61000-4-4 EFT: Power: 4 kV; Signal: 4 kV IEC 61000-4-5 Surge: Power: 2 kV; Signal: 2 kV IEC 61000-4-6 CS: 150 kHz to 80 MHz: 10 V/m; Signal: 10 V/m IEC 61000-4-8 PFMF
Hazardous Locations	ATEX, Class I Division 2, IECEx
Freefall	IEC 60068-2-32

Shock	IEC 60068-2-27
Vibration	IEC 60068-2-6 IEC 60068-2-64
<b>MTBF</b>	
Time	718,131 hrs
Standards	Telcordia SR332
<b>Warranty</b>	
Warranty Period	5 years
Details	See <a href="http://www.moxa.com/warranty">www.moxa.com/warranty</a>
<b>Package Contents</b>	
Device	1 x MGate 5111 Series gateway
Documentation	1 x quick installation guide 1 x warranty card

## Dimensions

Unit: mm (inch)

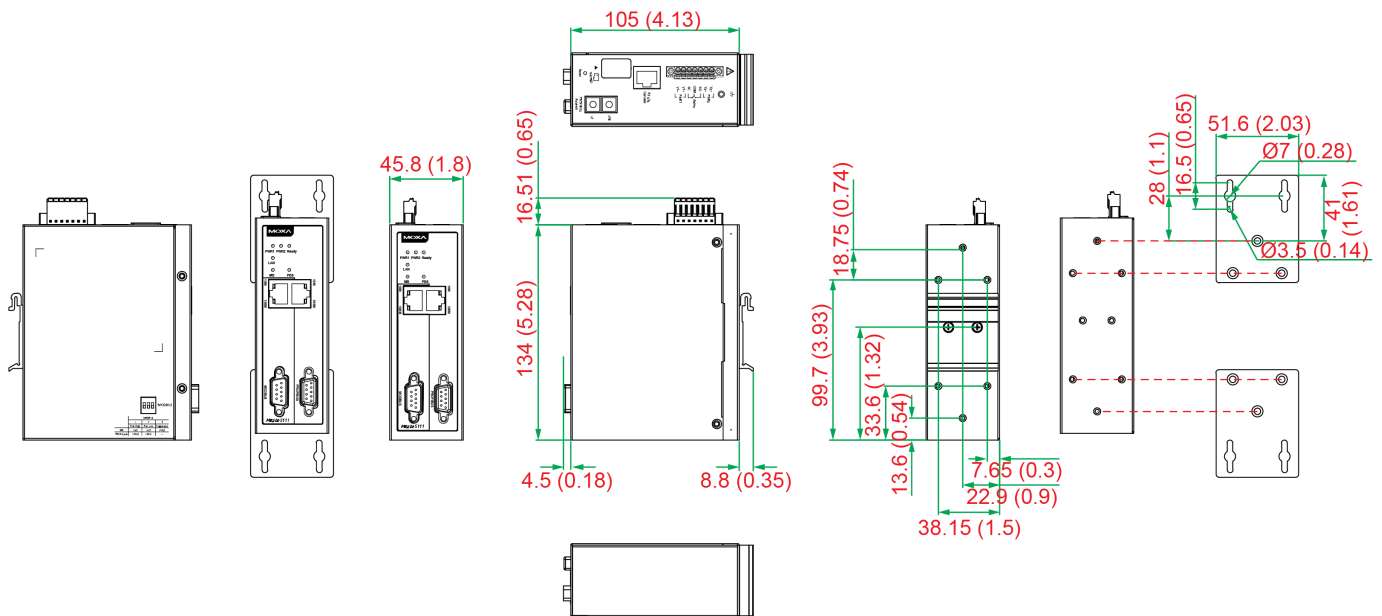

## Ordering Information

Model Name	Operating Temp.
MGate 5111	0 to 60°C
MGate 5111-T	-40 to 75°C

## Accessories (sold separately)

### Cables

CBL-F9M9-150	DB9 female to DB9 male serial cable, 1.5 m
CBL-F9M9-20	DB9 female to DB9 male serial cable, 20 cm
CBL-RJ45F9-150	RJ45 to DB9 female serial cable, 1.5 m

CBL-RJ45SF9-150	RJ45 to DB9 female serial shielded cable, 1.5 m
-----------------	---

#### Connectors

Mini DB9F-to-TB	DB9 female to terminal block connector
-----------------	--

#### Wall-Mounting Kits

WK-51-01	Wall-mounting kit, 2 plates, 6 screws, 51.6 x 67 x 2 mm
----------	---

#### Power Cords

CBL-PJTB-10	Non-locking barrel plug to bare-wire cable
-------------	--

© Moxa Inc. All rights reserved. Updated Nov 12, 2018.

This document and any portion thereof may not be reproduced or used in any manner whatsoever without the express written permission of Moxa Inc. Product specifications subject to change without notice. Visit our website for the most up-to-date product information.